



振安流量

www.shanghaizhenan.com

LDG型智能电磁流量计

Intelligent Electromagnetic Flowmeter

上海振安流量仪表厂

地址：上海市奉贤区星火开发区民乐路328号21-22栋

电话：021-56084666 56084777

传真：021-56084999

邮编：201419



<http://www.shanghaizhenan.com>

<http://www.zhenan88.com>

E-mail: sale@shanghaizhenan.com



沪制01060124号

上海振安流量仪表厂

Shanghai zhenan Flowmeter Co.,Ltd.



www.shanghaizhenan.com

上海振安流量仪表厂专业从事流量仪表的研发、制造、销售及售后服务，近几年来，凭借过硬的产品质量和优质的服务赢得了全国广大用户良好的口碑，在全国流量仪表行业享有较高的知名度，现有我公司生产的涡街流量计年产量在几千台，智能电磁流量计的销售正以倍数在增长，智能流量积算仪在全国几十家(生产流量计厂家)配套使用。

随着市场竞争日益激烈，经济的迅速发展，我公司积极引进国外技术，扩展技术质量，严把质量关，从采购原料、生产、安装、调试、检测一条龙的生产流水线，同时我公司拥有专业检定测试装置，每台产品都必须经过严格检测、标定才可以出厂，只有严把质量关，公司才得以迅速发展，提高产品质量，推动流量仪表的日益进步，让我们共同创造流量仪表行业美好未来，无论是现在，还是将来，时刻竭诚为您服务！

- >>> 希望有机会与您合作
- >>> 欢迎您来我公司实地考察
- >>> 质量与价格都具有很大的竞争力

Our company is specialized in the research and development, manufacture, sales and service of flowmeters, thriving on word-of-mouth referrals from a nationwide range of satisfied users and enjoying high prestige in the industry of domestic flowmeter in recent years by virtue of excellent product quality and high-quality service. Currently, the vortex flowmeter manufactured by our company has the annual output of several thousand sets, the sales amount of the intelligent electromagnetic flowmeter is being increased exponentially, and the intelligent flow totalizer has been applied as support equipment in scores of flowmeter manufacturers in China.

As the market competition becomes more and more fierce and the economy develops rapidly, our company initiatively introduces foreign technology, improve technical quality, check the quality of production chain rigidly from the procurement of raw materials, production, installation, commissioning and testing; meanwhile, our company has professional devices for detection and testing, so that each product should not be delivered until it has passed rigid testing and been calibrated. Only depending on the rigid quality checkup, can the company develop rapidly, so as to enhance the quality of products and promote the progress of flowmeters. Let's create a bright future for the industry of flowmeters together, and we are always ready to serve you sincerely now and in the future!

- >>> Looking forward to cooperating with you
- >>> Welcome to make a on-site survey in our company
- >>> Both our quality and price have great competitiveness

电磁流量计工作原理

Working Principle of Electromagnetic Flowmeter

工作原理基于法拉第电磁感应定律。即当导电液体流过电磁流量计时，导体中会产生感应电动势，其感应电动势与导电液体流速、磁感应强度、导体宽度（流量计内径）成正比。

该感应电动势由流量计管壁上的一对电极检测到，通过运算就可以得到流量。感应电动势方程为：

The working principle is based on Faraday's Law of Electromagnetic Induction, that is, when the conductive liquid flows through the electromagnetic flowmeter, the induced electromotive force will be produced in the conductor, and the induced electromotive force is directly proportional to the flow velocity of conductive liquid, magnetic flux density and width of conductor (inside diameter of flowmeter).

Such induced electromotive force is detected by a pair of electrode on the tube wall of the flowmeter, and the rate of flow can be acquired by mathematical operation. The equation of induced electromotive force is as follows:

$$E = D \cdot V \cdot B$$

其中：E：感应电动势 D：测量管内径 V：流速 B：磁感应强度为了获得满意的测量精度，必须满足以下条件：

- (1) 被测液体必须具有导电性；
- (2) 液体必须充满管道；
- (3) 液体成分必须均匀；
- (4) 如果液体导磁，流量计磁场将改变，必须对流量计进行修正。

Where, E: Induced Electromotive Force, D: Inside Diameter of Measuring Pipe, V: Flow Velocity, and B: magnetic flux density.

The following conditions should be satisfied in order to obtain satisfactory measuring accuracy:

- (1) The tested liquid shall possess the electrical conductivity;
- (2) The pipe shall be full of liquid;
- (3) The components of liquid shall be well mixed;
- (4) If the liquid induces magnetic, the magnetic field of the flowmeter will change, so the flowmeter shall be adjusted.

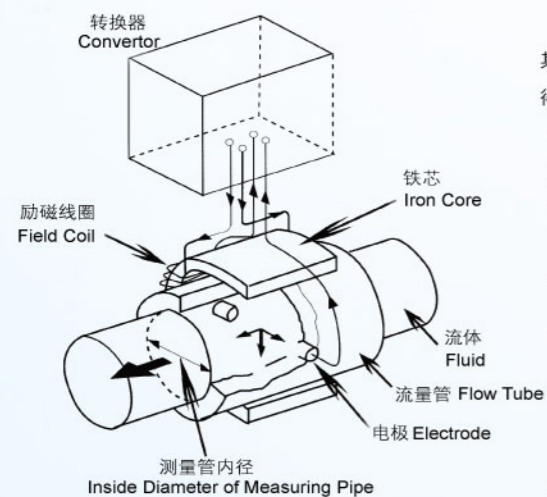

流量每一处 精确每一度

It can measure the flow at every position at high precision

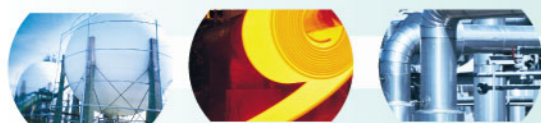
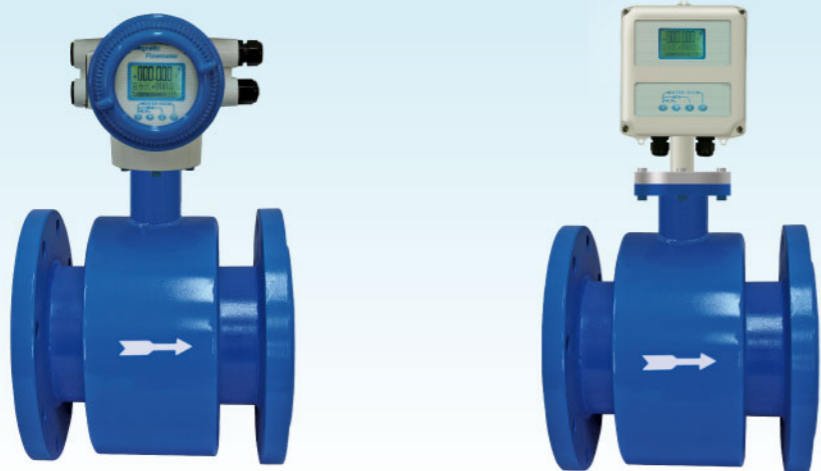

www.shanghaizhenan.com

口径	10-3200	Aperture	10-3200
励磁方式	双向恒流方波励磁	Excitation System	Bidirectional Constant Flow Squarewave Excitation
安装形式	一体型	Installation Form	Integral
衬里	氯丁橡胶, PTFE	Lining	Chloroprene Rubber, PTFE
电极材料	316L, HC, HB, 钛, 钽, 铂铱	Material of Electrode	316L, HC, HB, Titanium, Tantalum, Platiniridium
接地	内置接地电极	Grounding	Built-in Grounding Electrode
介质	导电性液体	Medium	Conductive Liquid
精度等级	0.2, 0.5, 1.0	Grade of Accuracy	0.2, 0.5, 1.0
介质电导率	>5 μ S/cm	Conductibility of Medium	>5 μ S/cm
流速	\leq 15m/s	Flow Velocity	\leq 15m/s
管道连接法兰	GB9119-2000或GB9115-2000	Flange of Pipe Connection	GB9119-2000 or GB9115-2000
管道连接	法兰连接	Pipe Connection	Flange Connection
介质温度	氯丁橡胶: -10 $^{\circ}$ C~+60 $^{\circ}$ C; PTFE: -10 $^{\circ}$ C~+120 $^{\circ}$ C	Temperature of Medium	Chloroprene Rubber: -10 $^{\circ}$ C~+60 $^{\circ}$ C; PTFE: -10 $^{\circ}$ C~+120 $^{\circ}$ C
额定压力	4MPa, 1.6MPa, 1.0MPa	Rated Voltage	4MPa, 1.6MPa, 1.0MPa
防护类别	IP65, IP68	Category of Shielding	IP65, IP68
输出信号	4~20mA电流, 脉冲, 上下限报警	Output Signal	4~20mA Current, Pulse, Warning beyond upper and lower limits
电缆接口	G1/2内螺纹	Cable Interface	G1/2 Female Thread
通讯	RS485通讯协议	Communication	RS485 Protocol
显示器显示	瞬时流量, 百分比, 流速, 正反向累积流量和总累积量	Display of Monitor	Transient Flow, Percentage, Flow Velocity, Forward and Reverse Integrated Flux and Total Integrated Flux
电源	220V AC, 24V DC	Power Supply	220V AC, 24V DC
使用类型	一般型, 防水型	Type of Application	General Type, Waterproof Type
*高压	定做	* High Voltage	Custom-made



口径	10-3200	Aperture	10-3200
励磁方式	双向恒流方波励磁	Excitation System	Bidirectional Constant Flow Squarewave Excitation
安装形式	分体型	Installation Form	Split
衬里	氯丁橡胶, PTFE	Lining	Chloroprene Rubber, PTFE
电极材料	SUS316L, HC, HB, 钛, 钽, 铂铱	Material of Electrode	316L, HC, HB, Titanium, Tantalum, Platiniridium
接地	内置接地电极	Grounding	Built-in Grounding Electrode
介质	导电性液体	Medium	Conductive Liquid
精度等级	0.2, 0.5, 1.0	Grade of Accuracy	0.2, 0.5, 1.0
介质电导率	>5 μ S/cm	Conductibility of Medium	>5 μ S/cm
流速	\leq 15m/s	Flow Velocity	\leq 15m/s
管道连接法兰	GB9119-2000或GB9115-2000	Flange of Pipe Connection	GB9119-2000 or GB9115-2000
管道连接	法兰连接	Pipe Connection	Flange Connection
介质温度	氯丁橡胶: -10 $^{\circ}$ C~+60 $^{\circ}$ C; PTFE: -10 $^{\circ}$ C~+120 $^{\circ}$ C	Temperature of Medium	Chloroprene Rubber: -10 $^{\circ}$ C~+60 $^{\circ}$ C; PTFE: -10 $^{\circ}$ C~+120 $^{\circ}$ C
额定压力	4MPa, 1.6MPa, 1.0MPa	Rated Voltage	4MPa, 1.6MPa, 1.0MPa
防护类别	IP65, IP68	Category of Shielding	IP65, IP68
输出信号	4~20mA电流, 脉冲, 上下限报警	Output Signal	4~20mA Current, Pulse, Warning beyond upper and lower limits
电缆接口	G1/2内螺纹	Cable Interface	G1/2 Female Thread
通讯	RS485通讯协议	Communication	RS485 Protocol
显示器显示	瞬时流量, 百分比, 流速, 正反向累积流量和总累积量	Display of Monitor	Transient Flow, Percentage, Flow Velocity, Forward and Reverse Integrated Flux and Total Integrated Flux
电源	220V AC, 24V DC	Power Supply	220V AC, 24V DC
使用类型	一般型, 防水型	Type of Application	General Type, Waterproof Type
*高压	定做	* High Voltage	Custom-made



目录 Contents

02 特点	02 Features
03 技术指标	03 Technical Index
04 正常工作条件、安装和结构	04 Normal Working Conditions, Installation and Structure
05 如何正确选型	05 How to Choose a Right Model
07 接线须知	07 Instruction to Wiring
08 电磁流量计工作状态时显示和设置说明	08 Display and Setup Instruction of Electromagnetic Flowmeter in the Working Condition
26 流量计型号说明	26 Instruction of Flowmeter Models
27 一体式流量计外形尺寸	27 Overall Dimension of Integral Flowmeter
28 技术资料	28 Technical Data

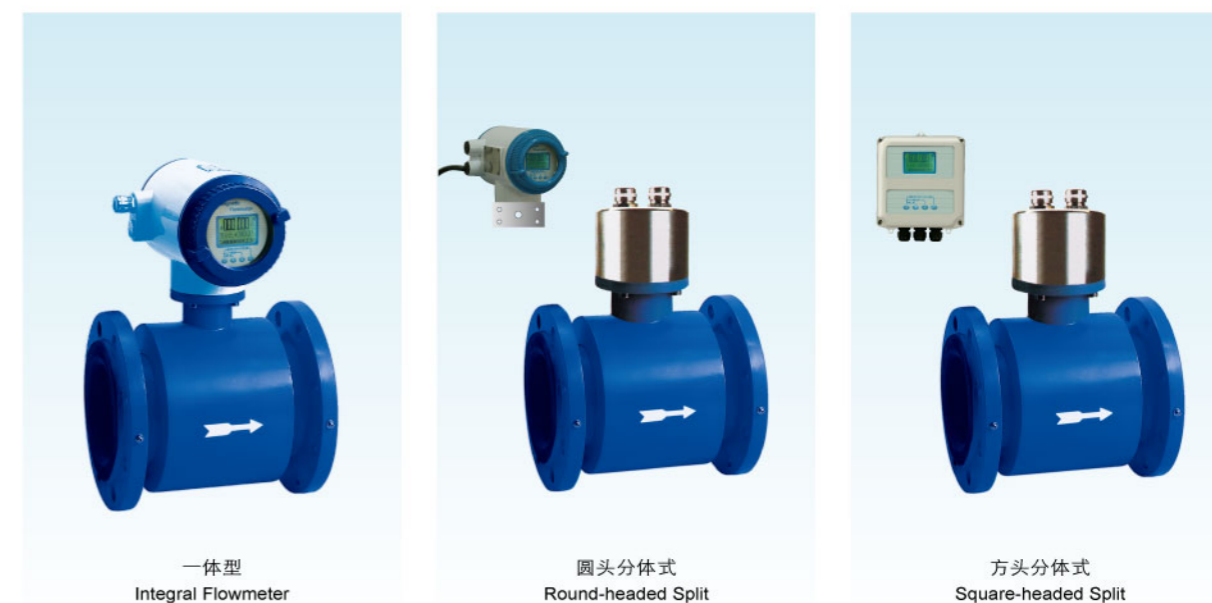

电磁流量计在流量仪表领域中多年经验的结晶，其设计与质量控制体系保证了产品的高精度和高可靠性，具有快速响应和消除输出噪声功能，而且可采用衬里，从而使得该电磁流量计的应用更加广泛。

The electromagnetic flowmeter, as the product of long-term experience in the field of flow instrument, has the functions of rapid response and output noise elimination. Its design and quality control system have guaranteed the high accuracy and reliability of the product, and the application of lining makes the electromagnetic flowmeter applied more widely.

特点:

- 提高了流量测量的稳定性
- 快速响应和高稳定性，甚至对于高浓度浆液和低电导率流体也如此
- 高可靠性电极结构
- 可采用衬里和内置接地电极
- 口径从10mm到3200mm
- 交、直流电源均可使用
- 多功能智能转换器
- 断电时，EEPROM可保护设定参数和累积值
- 高清晰度LCD背光显示

Features:

- The stability of flux measurement has been improved.
- Rapid response and high stability, even for highly concentrated serous fluid and fluid with low conductivity.
- Electrode structure with high reliability.
- Lining and built-in grounding electrode are both applicable.
- Diameter from 10mm to 3200mm.
- Both AC and DC power supplies are available.
- Multi-functional Intelligent Converter.
- When in power failure, EEPROM may protect the set parameters and accumulated values.
- High-definition LCD Backlight Display.

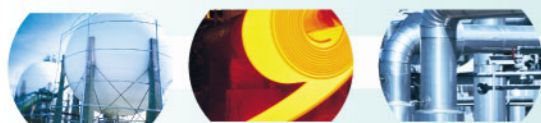

技术指标

电磁流量转换器部件技术指标

输入信号：来自检测器的与流量成正比的信号

输出信号：4~20mA DC
(负载电阻0~750)

通过参数设定选择脉冲/报警输出

脉冲输出/报警输出：(额定值：30VDC, 200mA)

通信信号(选择功能)

电脑通信信号(叠加在4~20mA DC信号上)

负载电阻：205~600 (包括电缆电阻)

负载电容：最大0.22μF

负载电感：最大3.3mH

电缆线间距：≥15cm (以避免平行布线)

接收仪表的输入阻抗：≥10k (在2.4kHz时)

最大电缆长度：2km (使用“CEV”电缆时)

量程范围设定功能：

通过设定体积单位，流量值和流量计口径来设定体积流量

体积单位：m³

速度单位：m/s

流量计口径：mm

瞬时流量显示功能：显示流量单位显示，也显示量程百分比

累积流量显示功能：可以显示正，反向累积值和总累积值

脉冲输出功能：通过设定一个脉冲系数就可以输出代表任何流量单位所表示的脉冲量

脉冲宽度：占空比50%或固定脉冲宽度供用户选择

输出速率：10-400 (脉冲数/秒) (只有在选择脉冲输出方式时使用)

失电数据保护：由EEPROM贮存数据，无需备用电池

正、反流量测量功能：在正、反流向测量模式中，可以测量反向流量

上限报警：流量大于上限设定值

下限报警：流量小于下限设定值

阻尼功能：可设定范围从0.2秒~100秒 (63%响应时间)

Technical Index

Technical Index of Electromagnetic Flow Converter Components.

Input Signal: Signal emitted from the detector and is directly proportional to the flux.

Output Signal: 4~20mA DC
(Load Resistance 0~750)

Choose the pulse/warning output by parameter setup.

Pulse Output/Warning Output: (Rated Value: 30VDC, 200mA)

Communication Signal (Function Selection)

Signal of Computer Communication (Superposed to Signal of 4~20mA DC).

Load Resistance: 205~600 (Including cable resistance)

Load Capacitance: Maximum 0.22μF

Load Inductance: Maximum 3.3mH

Space between Cables: ≥15cm (so as to avoid parallel wiring)

Input Impedance of Receiving Instrument: ≥10k (When 2.4kHz)

Maximum Length of Cable: 2km (When "CEV" cable is used)

Setup of Measurement Range:

The volumetric flux is set by the setup of volume unit, flow value and diameter of flowmeter.

Volume Unit: m³

Velocity Unit: m/s

Diameter of Flowmeter: mm

Display of Transient Flow: The flow unit and the range percentage are displayed.

Display of Integrated Flux: The forward and reverse integrated flux and total integrated flux are displayed.

Pulse Output: The pulse quantity expressed in any flux unit may be output by the setup of an impulse ratio.

Width of Pulse: Duty ratio of 50% or fixed pulse width is available for users to choose.

Output Speed: 10-400 (PPS) (Only applicable when the form of pulse output is selected).

Black-out Data Protection: Data will be stored by EEPROM without backup battery.

Forward and Reverse Flux Measurement: In the model of forward and reverse flow direction, the reverse flux may be measured.

Upper Limit Warning: The flux is larger than the upper limit of setting value.

Lower Limit Warning: The flux is smaller than the lower limit of setting value.

Function of Damping: The scope may be set from 0.2 second to 100 seconds (63% response time)

正常工作条件：

环境温度：-20~60℃

电源电压的额定值：

220V AC型：100V~240VAC

DC型：24V DC

Normal Working Conditions:

Ambient Temperature: -20~60℃

Rated Voltage of Power Supply:

220V AC: 100V~240VAC

DC: 24 VDC

安装和结构

安装：

分离型：转换器，50mm管道或平面安装

组合型：与传感器装成一体

导线接口：ISO M 20×1.5内螺纹

接线端子：M3螺钉

壳体材料：铝合金

结构：

一般型：防护等级IP65

防水型：(IP68)

Installation and Structure

Installation:

Separate Model: Converter, 50mm pipe or plane installation

Combined Model: Combined with Sensor

Wire Connector: ISO M 20 × 1.5 Female Thread

Wiring Terminal: M3 Screw

Material of Shell: Aluminium Alloy

Structure:

General Model: Degree of Protection IP65

Waterproof Model: (IP68)



www.shanghaizhenan.com

如何正确选型

流量计的选型是仪表应用中非常重要的工作，据有关资料表明，仪表在实际应用中有2/3的故障是仪表的错误选型和错误的安装而造成的，请特别注意。

1、收集数据

- ① 被测流体名称；
- ② 最大流量、最小流量；
- ③ 最高工作压力；
- ④ 最高温度、最低温度。

2、被测流体必须具备一定的导电性，导电率 $\geq 5\mu S/cm$ 。

3、最大流量和最小流量必须符合下页中的数值。

4、实际最高工作压力必须小于流量计的额定工作压力。

5、最高工作温度和最低工作温度必须符合流量计规定的温度要求。

6、确定是否有负压情况存在。

您可以根据上表中的流量选择相应的电磁流量计，若所选择的电磁流量计的内径与现在工艺管道的内径不符，应进行缩管或扩管。

1、若管道进行缩管，应考虑由于缩管引起的压力损失是否会影响工艺流程。

2、从产品价格上考虑，可以选择较小口径的电磁流量计，相对减少投资。

3、测洁净水时，经济流速是2~3m/s，测易结晶的溶液时，应适当地提高流速，以防止电磁流量计的电极被覆盖。

How to Choose A Right Model

The Flowmeter model selection is very important in the application of instrument. The related information shows that in the practical application of instrument, 2/3 troubles are caused by incorrect selection of model and incorrect installation of instrument to which the special attention shall be paid.

1. Data Collection

- ① Name of measured liquid;
- ② Maximum flux and minimum flux;
- ③ Maximum working pressure; and
- ④ Maximum and minimum temperatures.

2. The measured liquid shall have a certain conductivity, with conductivity $\geq 5\mu S/cm$.

3. The maximum flux and the minimum flux shall meet the values specified in the following page.

4. The actual maximum working pressure shall be less than the rated working pressure of the flowmeter.

5. The maximum and minimum working temperatures shall meet the temperature requirement stipulated for flowmeter.

6. Whether negative pressure exists or not shall be confirmed.

You may choose a corresponding electromagnetic flowmeter according to the fluxes in the above table, and if the inside diameter of the selected electromagnetic flowmeter is different from that of the tube under existing process, the tube reduction or expansion shall be considered.

1. In case of tube reduction, whether the pressure loss caused by tube reduction will affect the process flow or not shall be considered.

2. If the price of product is considered, the electromagnetic flowmeter with smaller diameter may be selected to reduce investment relatively.

3. When the uncontaminated water is measured, the economic velocity is 2~3m/s, and when the solution which is easy to crystalize is measured, the velocity shall be increased appropriately so as to prevent the electrode of electromagnetic flowmeter from being covered.

可测流量范围 Range of Measurable Flux

国际单位 (口径: mm, 流量: m³/h)
International Unit (Caliber: mm, Flux: m³/h)

口径 Caliber (mm)	0—最小流量 Range of Minimum 量程 Flux (0.1m/s)	0—最大流量 Range of Maximum 量程 Flux (10m/s)
10	0.0283	2.8274
15	0.0636	6.3615
20	0.1131	11.3094
25	0.1767	17.6709
32	0.2895	28.9521
40	0.4524	45.2376
50	0.7068	70.6838
65	1.1946	119.4555
80	1.8095	180.9504
100	2.8274	282.7350
125	4.4177	441.7734
150	6.3615	636.1538
200	11.3094	1130.9400
250	17.6709	1767.0938
300	25.4462	2544.6150
350	34.6350	3463.5038
400	45.2376	4523.7600
500	70.6838	7068.3750
600	101.7846	10178.4600
700	138.5402	13854.0150
800	180.9504	18095.0400
900	229.0154	22901.5350
1000	282.7350	28273.5000

口径 Caliber (mm)	0—最小流量 Range of Minimum 量程 Flux (0.3m/s)	0—最大流量 Range of Maximum 量程 Flux (10m/s)
1100	1026.3281	34210.9350
1200	1221.4152	40713.8400
1400	1662.4818	55416.0600
1500	1908.4613	63615.3750
1600	2171.4048	72380.1600
1800	2748.1842	91606.1400
2000	3392.8200	113094.0000
2200	4105.3122	136843.7400
2400	4885.6608	162855.3600
2600	5733.8658	191128.8600



为保护操作人员和维修人员不遭受电击以及防止外部噪声的影响，应将接地连接到 ⊕ 标志上 ($\leq 100\Omega$)
 To protect the operators and the maintenance personnel from electric shock and shield external noises, the earthing wire should be connected to the sign ⊕ ($\leq 100\Omega$).

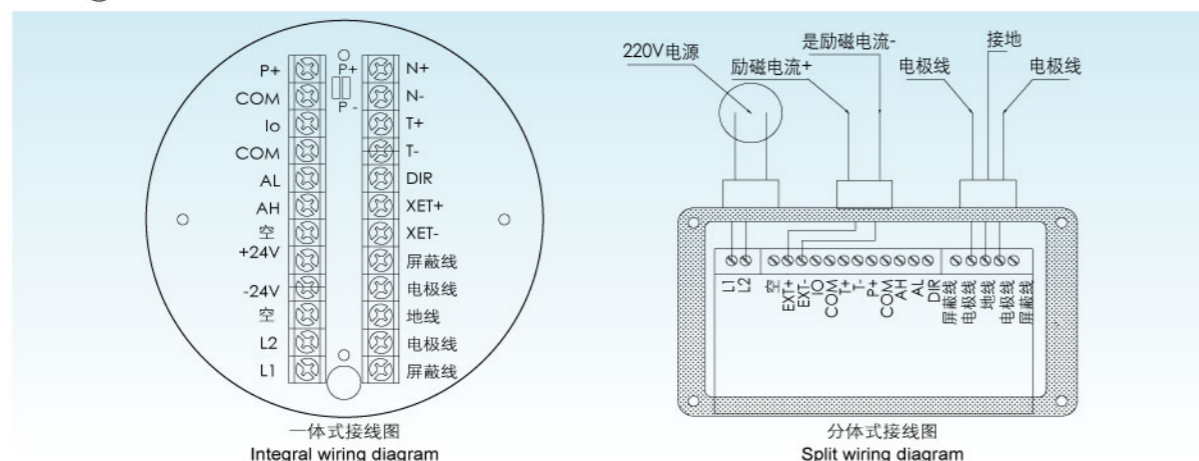

端子符号说明 Symbolic description of terminal

Terminal Symbol	Function specification	Terminal Symbol	Function specification
1 P+	双向流量脉冲输出/频率输出 Bi-directional flux pulse output/frequency output	N+	正反流量输出功能端口 Forward and reverse flow output functional port
2 COM		N-	
3 IO	4-20mA电流输出 4-20mA current output	T+	RS485通讯输出 RS485 Communication output
4 COM		T-	
5 AL	流量下限报警输出 Alarm output for lower limit of flux	DIR	
6 AH	流量上限报警输出 Alarm output for upper limit of flux	XET+	励磁电流 Excitation current
7 空 Empty		XET-	
8 +24VDC	24V供电接入端 24V power supply access point	屏蔽线 Shielded wire	
9 -24VDC		电极线 Electrode wire	
10 空 Empty		地线 Earthing wire	
11 L2	220V供电接入端 220 power supply access point	电极线 Electrode wire	
12 L1		屏蔽线 Shielded wire	
中间短接件 Short circuit piece in between	当短接件接在上方 (P+)时流量输出为正流量，接下方 (P-)时输出为负流量 The flow output will turn out to be positive when the short circuit piece is connected to (P+) above, while negative for (P-) below.		

接线须知

接线时应注意以下几点:

- 为保证传感器接线盒内的绝缘性，防止由于潮湿引起的绝缘性不好，下雨天不要在室外连接电缆。
- 连接电源电缆和信号电缆两头要包有圆形的接线片。
- 建议使用导线管。导线管采用厚的且坚固的钢管道或柔性金属管道均可。
- 所有的电源电缆和非4芯24V DC的信号电缆必须套以钢的导线管。
- 当备有防水密封塞和接头、防水塞时，应将防水密封塞拧紧，以保证盒子内不渗水。

Instructions to Wiring

The following suggestions should be followed in the wiring work:

- To protect the insulation within the terminal box of the sensor from being hit by humidity, it is suggested not to connect cables outdoor in rain.
- Circular lug plate should be wrapped around both ends of power cable and signal wire.
- Conduit tube is recommended. The tube can be thick and solid steel pipe or flexible metal pipe.
- All main cable and signal cables of non-four-core 24V DC must be sleeved in steel conduit tube.
- When there are sealing plugs, joint and waterproof plug, the sealing plug should be fastened to prevent the box from leaking.

电磁流量计工作状态时显示和设置说明

Display and Setup Instruction of Electromagnetic Flowmeter in Working Condition

工作状态时显示有三行:

Three lines displayed in working condition:

上行: 显示的是瞬时流量36.234m³/h, 数值前面的“+”“-”表示的是流量的正反方向
 Upper line: Instantaneous flux 36.234m³/h, the “+” and “-” in front of the figures refer to the forward or reverse direction of the flow.

中行: 显示有三项内容, 可以按第三个键“▲”来循环显示。
 Middle line: “▲” can be pressed to display the three items, one at a time.



一、百分比 +072.8%。此项表示瞬时流量运行在该表量程范围的百分比
 1、Percentage: +072.8%. This item shows the percentage within the measurement range during the running of the instantaneous flow

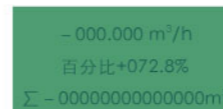

二、流速 +07.286 m/s。介质流经流量计的速度
 2、Flow speed: +07.286 m/s. The speed of the medium flowing through the flowmeter.

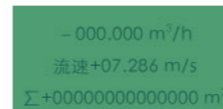

三、电阻 0009.8 KΩ。流经流量计介质的电阻值
 3、Resistance: 0009.8 KΩ. The resistance of the medium flowing through the flowmeter.



下行: 显示有七项内容, 可以按第二个键“▼”来循环显示
 Bottom line: “▼” can be pressed to display the seven items, one at a time.

一、Σ+00000002495.886 m³。正向流量的累积总量
 1、Σ+00000002495.886 m³. Accumulative amount of forward direction flow

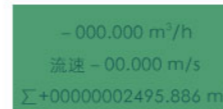

二、Σ-00000000005.886 m³。反向流量的累积总量
 2、Σ-00000000005.886 m³. Accumulative amount of reverse direction flow

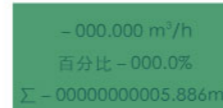

三、Δ±00000002490.000 m³。正向和反向累积总量相加的结果
 3、Δ±00000002490.000 m³. The accumulative amount of both forward and reverse direction flows

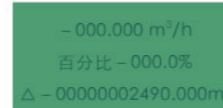

四、励磁正常/励磁报警

励磁正常/励磁线圈或相关出现部件异常

4、Normal excitation/excitation alarm
 Normal excitation/abnormal field coil or related parts





www.shanghaizhenan.com

-000.000 m³/h
百分比 -000.0%
空管正常

五、空管正常/空管报警

管道内流体满足测量要求/测量管道内无被测介质或被测介质未满管

5、Normal Hollow conduit/Hollow conduit alarm

Fluid inside the conduit satisfying measuring requirements/No medium to be measured inside the conduit or the medium does not fill the conduit

-000.000 m³/h
百分比 -000.0%
流量正常

六、流量正常

流量低于下限流量或者高于上限流量

6、Normal flux

The flux below lower limit or above upper limit

-000.000 m³/h
百分比 -000.0%
电极正常

七、电极正常/电极报警

电极正常/测量电极出现异常

7、Normal electrode/electrode alarm

Normal electrode/the measured electrode becomes abnormal

右上角: 若仪表出现报警状态, 右上角会出现警铃标志, 正常工作状态时一直显示电池电量条, 报警状态时电量条和电磁流量计参数设置菜单及按键说明。

Top right corner: If the meter alarms, the alarm bell will be revealed on the top right corner. In normal working conditions, the battery meter band will be displayed; in alarm conditions, the setup menu and button specifications for the meter band and electromagnetic flow meter index will be displayed.

按键及按键组合说明 Introductions to keys and key combinations

- ⏏ 是功能键 在组合键时使用 Functional key, used in key combinations
- ⏴ 是下翻键 数字状态下时9-0依次循环递减数字 Page down key. Numbers will be displayed from 9 to 0 in order when the key is used
- ⏵ 是上翻键 数字状态下时0-9依次循环递增数字 Page up key. Numbers will be displayed from 0 to 9 in order when the key is used
- SET 是确认键相当于回车键, 可以进入菜单项修改或退出进入菜单项修改
It's used for confirmation which equals to the Enter button. It may enter menu items or exit menu items for modification.
- ⏏ + SET 是使进入设置菜单 Access to Setup Menu
- ⏏ + ⏴ 是使光标前移的键 Keys to move forward the cursor
- ⏏ + ⏵ 是使光标后移的键 Keys to move the cursor backwards

请输入密码:
9454

同时按 ⏏ 键和 SET 键进入密码设定。

进入设置菜单的密码是: 9454。

进入设置菜单后屏幕显示的4个数字是随机的, 您依次把这4个数字改为9454。

然后按 SET 键就进入设置菜单了。

To enter password Setting Interface by pressing ⏏ and SET .

9454 is the password to the setup menu.

Change the 4 random figures displayed into 9454 and then press SET to enter Setup Menu.

语言选择
中文

语言选择
English

菜单内容和内容说明:
The content of menu and specification:

一、语言选择

按 SET 键进入该项设置状态。

按 ⏴ 或 ⏵ 键在2个中文 English 选项中选择, 此项中设置的是整个菜单界面所需要显示的语言。

按 SET 键退出该项设置状态。

按 ⏴ 或 ⏵ 键选择下一选项或者上一选项, 这里按 ⏴ 选择下一选项二。

1、Language selection

Press SET to enter the Language Setting Interface.

Press ⏴ or ⏵ to choose between English and Chinese language in which the entire menu interface will be displayed.

Press SET to exit the Language Setting Interface.

Press ⏴ or ⏵ to choose the former or the next item. Here ⏴ can be pressed to choose item 2 below.

选择测量管道口径
100

二、选择测量管道口径

按 SET 键进入该项设置状态。

按 ⏴ 或 ⏵ 键在 3, 6, 8, 10, 15, 20, 25, 32, 40, 50, 65, 80, 100, ...3200。中选择你实际使用的口径。

按 SET 键退出该项设置状态。

按 ⏴ 或 ⏵ 键选择下一选项或者上一选项, 这里按 ⏴ 选择下一选项三。

2、Choose the caliber of the measuring pipe

Press SET to enter the Language Setting Interface.

Press ⏴ or ⏵ to choose the caliber actually needed from 3, 6, 8, 10, 15, 20, 25, 32, 40, 50, 65, 80, 100,... 3200.

Press SET to exit the Language Setting Interface.

Press ⏴ or ⏵ to choose the former or the next item. Here ⏴ can be pressed to choose item 3 below.

仪表量程设置
000200.00000m³/h

三、仪表量程设置

按 SET 键进入该项设置状态。

参照按键说明, 修改此项数值到您需要的值, 此项值是指仪表测量的上限流量值(满量程), 此项设置不影响流量计本身测量值, 但仪表的电流输出, 频率(脉冲)输出以此为基础。

按 SET 键退出该项设置状态。

按 ⏴ 或 ⏵ 键选择下一选项或者上一选项, 这里按 ⏴ 选择下一选项四。

3、Setup of instrument range

Press SET to enter the Language Setting Interface.

With reference to the keystroke instruction, modify the numerical value to your desired value; the figure refers to the upper limit flux of the flowmeter. This setup will not influence the measuring value of the flowmeter, but it will become the basis for the current output of the flowmeter and frequency (pulse) output.

Press SET to exit the Language Setting Interface.

Press ⏴ or ⏵ to choose the former or the next item. Here ⏴ can be pressed to choose item 4 below.



流量零点手动修正
基准 -0000.000
+0000.000

四、流量零点手动修正

此值为出厂校准用，用户不得更改。

按 **SET** 键进入该项设置状态。

在修改此值前必须保证满管且管道内流体保持在静止状态。

参照按键说明，修改此项数值到基准为零即可。

按 **SET** 键退出该项设置状态。

按 **▲** 或 **▼** 键选择下一选项或者上一选项，这里按 **▲** 选择下一选项五。

4、Setting the zero point of flux manually

This value is used for calibration before leaving the factory, not allowed to be modified by users.

Press **SET** to enter the Language Setting Interface.

The conduit must be fully packed and the fluid inside the conduit must be static before setting the above value.

Set and adjust the value until the benchmark figure points at zero according to the button specification.

Press **SET** to exit the Language Setting Interface.

Press **▲** or **▼** to choose the former or the next item. Here **▲** can be pressed to choose item 5 below.

测量阻尼时间
4.0S

五、测量阻尼时间

按 **SET** 键进入该项设置状态。

按 **SET** 键退出该项设置状态。

按 **▲** 或 **▼** 键在 0.2S, 0.5S, 0.8S, 1S, …… 100S 中选择。测量阻尼时间增大，能提高仪表流量和输出信号的稳定性，当仪表有脉冲输出时，脉冲间隔时间应小于阻尼时间。

按 **▲** 或 **▼** 键选择下一选项或者上一选项，这里按 **▲** 选择下一选项六。

5、Measure damping time

Press **SET** to enter the Language Setting Interface.

Press **SET** to exit the Language Setting Interface.

Press **▲** or **▼** to choose from 0.2S, 0.5S, 0.8S, 1S, …… 100S. An increased damping time may increase the flux of the meter and improve the stability of the output signal. When there is pulse output within the meter, the interval of pulse should be less than the damping time.

Press **▲** or **▼** to choose the former or the next item. Here **▲** can be pressed to choose item 6 below.

小信号切除点
00.5%

六、小信号切除点

按 **SET** 键进入该项设置状态。

参照按键说明，修改此项数值到您需要的值，此项是在流量计受到轻微干扰时设置的，此项切除的是量程设置中设置值的百分比。所有低于此值的瞬时流量都将显示零且不累积流量。

按 **SET** 键退出该项设置状态。

按 **▲** 或 **▼** 键选择下一选项或者上一选项，这里按 **▲** 选择下一选项七。

6、Dwarf signal removal point

Press **SET** to enter the Language Setting Interface.

With reference to the keystroke instruction, modify the numerical value to your desired value; the figure is set when the flowmeter is slightly disturbed and the removed part is the percentage of the measuring range value. All instantaneous fluxes below this figure will come down to zero and will not be accumulated.

Press **SET** to exit the Language Setting Interface.

Press **▲** or **▼** to choose the former or the next item. Here **▲** can be pressed to choose item 7 below.

小信号切除方式
允许

七、小信号切除方式

按 **SET** 键进入该项设置状态。

按 **▲** 或 **▼** 键，选择允许禁止，此项设置禁止后，小信号切除点中的设置将无效。

按 **SET** 键退出该项设置状态。

按 **▲** 或 **▼** 键选择下一选项或者上一选项，这里按 **▲** 选择下一选项八。

7、Method for removing dwarf signal

Press **SET** to enter the Language Setting Interface.

Press **▲** or **▼** to choose between Permit and Prohibit. If prohibit is chosen, the setup for dwarf signal removal point will be invalid.

Press **SET** to exit the Language Setting Interface.

Press **▲** or **▼** to choose the former or the next item. Here **▲** can be pressed to choose item 8 below.

选择流量方向
正向

八、选择流量方向

按 **SET** 键进入该项设置状态。

按 **▲** 或 **▼** 键，选择正向反向，此项设置将改变显示流量的正、负方向。

按 **SET** 键退出该项设置状态。

按 **▲** 或 **▼** 键选择下一选项或者上一选项，这里按 **▲** 选择下一选项九。

8、Choose directions of the flux

Press **SET** to enter the Language Setting Interface.

Press **▲** or **▼** to choose between "Forward" and "Reverse", which will change the directions of the flux to either forward or reverse direction.

Press **SET** to exit the Language Setting Interface.

Press **▲** or **▼** to choose the former or the next item. Here **▲** can be pressed to choose item 9 below.

反向测量允许
允许

九、反向测量允许

按 **SET** 键进入该项设置状态。

按 **▲** 或 **▼** 键，选择允许禁止，此项设置如果设置为禁止，则反向流量将不显示且不累积反向流量。

按 **SET** 键退出该项设置状态。

按 **▲** 或 **▼** 键选择下一选项或者上一选项，这里按 **▲** 选择下一选项十。

9、Reverse measure permit

Press **SET** to enter the Language Setting Interface.

Press **▲** or **▼** to choose between Permit and Prohibit. If prohibit is chosen, the reverse flux will not be revealed and accumulated.

Press **SET** to exit the Language Setting Interface.

Press **▲** or **▼** to choose the former or the next item. Here **▲** can be pressed to choose item 10 below.

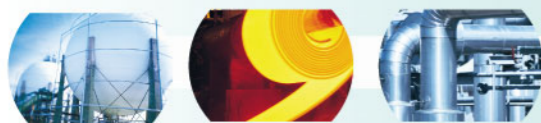

电流输出类型
4-20mA

十、电流输出类型

按 **SET** 键进入该项设置状态。

按 **▲** 或 **▼** 键，选择 4-20mA、0-10mA，两种电流输出方式，这两种方式对应的瞬时流量都是 0-量程设置里的上限流量。

按 **SET** 键退出该项设置状态。

按 **▲** 或 **▼** 键选择下一选项或者上一选项，这里按 **▲** 选择下一选项十一。

10. Mode of current output

Press **SET** to enter the Language Setting Interface.

Press **▲** or **▼** to choose between two modes of current output: 4-20mA and 0-10mA. The corresponding instantaneous flows of these two modes are all upper fluxes within the 0-range setup.

Press **SET** to exit the Language Setting Interface.

Press **▲** or **▼** to choose the former or the next item. Here **▲** can be pressed to choose item 11 below.

频率脉冲输出方式
频率

十一、频率脉冲输出方式

按 **SET** 键进入该项设置状态。

按 **▲** 或 **▼** 键，选择 频率、脉冲，两种电流输出方式。

脉冲输出方式有 2 种：脉冲输出和频率输出。脉冲输出为矩形波脉冲串，当仪表瞬时流量累积满一个脉冲当量时，就发出一个脉冲，频率输出为连续方波，输出频率的大小和瞬时流量和设置的上限流量，频率上限有关。

按 **SET** 键退出该项设置状态。

按 **▲** 或 **▼** 键选择下一选项或者上一选项，这里按 **▲** 选择下一选项十二。

11. Frequency pulse output mode

Press **SET** to enter the Language Setting Interface.

Press **▲** or **▼** to choose between two modes of current output: Frequency and Pulse.

There are two modes of pulse output: pulse output and frequency output. Pulse output is a pulse train of rectangular wave where one pulse will be delivered when the instantaneous flux amounts to one equivalent of pulse. While frequency output is successive square wave where the value of the output frequency and the instantaneous flux are associated with the preset upper limits of the flux and frequency.

Press **SET** to exit the Language Setting Interface.

Press **▲** or **▼** to choose the former or the next item. Here **▲** can be pressed to choose item 12 below.

脉冲宽度选择
10

十二、脉冲宽度选择

按 **SET** 键进入该项设置状态。

按 **▲** 或 **▼** 键，在 10、20、50、100、150、200、250、300、350、400 中选择，脉冲宽度的选择只在您选择了脉冲输出时有效，脉冲宽度是指方波的长度。

按 **SET** 键退出该项设置状态。

按 **▲** 或 **▼** 键选择下一选项或者上一选项，这里按 **▲** 选择下一选项十三。

12. Choose pulse width

Press **SET** to enter the Language Setting Interface.

Press **▲** or **▼** to choose from 10, 20, 50, 100, 150, 200, 250, 300, 350 and 400. Choosing of pulse width becomes valid only when you choose the pulse output. Pulse width refers to the length of the square wave.

Press **SET** to exit the Language Setting Interface.

Press **▲** or **▼** to choose the former or the next item. Here **▲** can be pressed to choose item 13 below.

脉冲单位当量
1L/P

十三、脉冲单位当量

按 **SET** 键进入该项设置状态。

按 **▲** 或 **▼** 键，在 0.001L/P、0.01L/P、0.1L/P、1L/P、2L/P、5L/P、10L/P、100L/P、1m³/p、10m³/p、100m³/p、1000m³/p 中选择，脉冲当量的选择只在您选择了脉冲输出时有效，脉冲单位当量是指每个脉冲所代表的累积流量值，用于机械式电磁计数器最高频率 25 次/秒。

按 **SET** 键退出该项设置状态。

按 **▲** 或 **▼** 键选择下一选项或者上一选项，这里按 **▲** 选择下一选项十四。

13. Unit equivalent of pulse

Press **SET** to enter the Language Setting Interface.

Press **▲** or **▼** to choose from 0.001L/P, 0.01L/P, 0.1L/P, 1L/P, 2L/P, 5L/P, 10L/P, 100L/P, 1m³/p, 10m³/p, 100m³/p and 1000m³/p. Choosing of pulse equivalent becomes valid only when you choose the pulse output. Unit equivalent of pulse refers to the accumulative flux each pulse represents. The highest frequency used in mechanical electromagnetic counter is 25 times/second.

Press **SET** to exit the Language Setting Interface.

Press **▲** or **▼** to choose the former or the next item. Here **▲** can be pressed to choose item 14 below.

频率输出范围
1000Hz

十四、频率输出范围

按 **SET** 键进入该项设置状态。

参照按键说明，修改此项数值到您需要的值。

频率输出范围的选择只在您选择了频率输出时有效，此项值是指当瞬时流量达到量程中设置的流量上限时，输出的频率值。

按 **SET** 键退出该项设置状态。

按 **▲** 或 **▼** 键选择下一选项或者上一选项，这里按 **▲** 选择下一选项十五。

14. Range of frequency output

Press **SET** to enter the Language Setting Interface.

With reference to the keystroke instruction, modify the numerical value to your desired value.

The choosing of frequency output range becomes valid only when you choose the frequency output. This figure refers to the frequency output when the instantaneous flux reaches the preset upper limits.

Press **SET** to exit the Language Setting Interface.

Press **▲** or **▼** to choose the former or the next item. Here **▲** can be pressed to choose item 15 below.

累积流量单位
0.001m³

十五、累积流量单位

按 **SET** 键进入该项设置状态

按 **▲** 或 **▼** 键选择：1L、0.1L、0.01L、0.001L；1m³、0.1m³、0.01m³、0.001m³；1KG、0.1KG、0.01KG、0.001KG；1T、0.1T、0.01T、0.001T。此设置能改变累积流量显示的小数点位置及单位。同时瞬时流量的单位会随累积流量的单位改变而改变。

按 **SET** 键退出该项设置状态。

按 **▲** 或 **▼** 键选择下一选项或者上一选项，这里按 **▲** 选择下一选项十六。

15. Accumulative flow units

Press **SET** to enter the Language Setting Interface.

Press **▲** or **▼** to choose: 1L, 0.1L, 0.01L, 0.001L; 1m³, 0.1m³, 0.01m³, 0.001m³; 1KG, 0.1KG, 0.01KG, 0.001KG; 1T, 0.1T, 0.01T, 0.001T. The setting may change the decimal point and unit of accumulative flux. At the same time, the unit of instantaneous flux will change with the unit of accumulative flux.

Press **SET** to exit the Language Setting Interface.

Press **▲** or **▼** to choose the former or the next item. Here **▲** can be pressed to choose item 16 below.



空管报警允许
允许

十六、空管报警允许

按 **SET** 键进入该项设置状态。

按 **▲** 或 **▼** 键选择：允许 禁止。

当选择允许时，若测量管道内非满管或被测量介质电导率太低，有可能被仪表判定为空管。瞬时流量被置为0且不累计流量。

按 **SET** 键退出该项设置状态。

按 **▲** 或 **▼** 键选择下一选项或者上一选项，这里按 **▲** 选择下一选项十七。

16、Hollow conduit alarm permit

Press **SET** to enter the Language Setting Interface.

Press **▲** or **▼** to choose: Permit or Prohibit.

When Permit is chosen and if the measured conduit is not fully packed or the conductivity of the measured medium is too low, the conduit may be regarded as hollow conduit and instantaneous flux comes down to zero and will not be accumulated.

Press **SET** to exit the Language Setting Interface.

Press **▲** or **▼** to choose the former or the next item. Here **▲** can be pressed to choose item 17 below.

空管阈值
0200.000%

十七、空管阈值

按 **SET** 键进入该项设置状态。

参照按键说明，修改此项数值到您需要的值。

空管检测是检测被测液体的电阻与实验室导电液体（一般式水约100 μ S/cm）的比值若测量出的比值大于此项设定值，就会被判定为空管。

按 **SET** 键退出该项设置状态。

按 **▲** 或 **▼** 键选择下一选项或者上一选项，这里按 **▲** 选择下一选项十八。

17、Threshold value of hollow conduit

Press **SET** to enter the Language Setting Interface.

With reference to the keystroke instruction, modify the numerical value to your desired value;

In the hollow conduit detection, it is to figure out the ratio between the resistance of the measured fluid and that of the conducting liquid (100 μ S/cm for normal water) in the laboratory. If the ratio turns out to be lower than the set value, the conduit will be regarded as hollow.

Press **SET** to exit the Language Setting Interface.

Press **▲** or **▼** to choose the former or the next item. Here **▲** can be pressed to choose item 18 below.

电极阈值
0200.000%

十八、电极阈值

按 **SET** 键进入该项设置状态。

参照按键说明，修改此项数值到您需要的值。

电极检测是检测实验室中电极的电阻与现场使用中电极的电阻的比值若测量出的比值大于此项设定值，就会出现电极异常的报警。

按 **SET** 键退出该项设置状态。

按 **▲** 或 **▼** 键选择下一选项或者上一选项，这里按 **▲** 选择下一选项十九。

18、Threshold value of electrode

Press **SET** to enter the Language Setting Interface.

With reference to the keystroke instruction, modify the numerical value to your desired value.

In electrode detection, it is to figure out the ratio between the resistance of the electrode in laboratory and that of the electrode at field service. If the ratios turn out to be above the set value, the electrode will alarm.

Press **SET** to exit the Language Setting Interface.

Press **▲** or **▼** to choose the former or the next item. Here **▲** can be pressed to choose item 19 below.

上限报警允许
禁止

十九、上限报警允许

按 **SET** 键进入该项设置状态。

按 **▲** 或 **▼** 键选择：允许 禁止。

当选择允许时，瞬时流量超过上限报警值时仪表就会发出报警信号，但不影响流量显示和累积。

按 **SET** 键退出该项设置状态。

按 **▲** 或 **▼** 键选择下一选项或者上一选项，这里按 **▲** 选择下一选项二十。

19、Upper limit alarm permits

Press **SET** to enter the Language Setting Interface.

Press **▲** or **▼** to choose: Permit or Prohibit.

If Permit is chosen, the flowmeter will give an alarm signal when the instantaneous flux surpasses the upper limit alarm value. However, the display and accumulation of flux will not be influenced.

Press **SET** to exit the Language Setting Interface.

Press **▲** or **▼** to choose the former or the next item. Here **▲** can be pressed to choose item 20 below.

上限报警阈值
120.0%

二十、上限报警阈值

按 **SET** 键进入该项设置状态。

参照按键说明，修改此项数值到您需要的值，此项设定值就是上限报警值，此值以量程的百分比计算。

按 **SET** 键退出该项设置状态。

按 **▲** 或 **▼** 键选择下一选项或者上一选项，这里按 **▲** 选择下一选项二十一。

20、Upper limit value of alarm threshold

Press **SET** to enter the Language Setting Interface.

With reference to the keystroke instruction, modify the numerical value to your desired value; this set value is the very upper limit alarm value and is calculated by percentage of measurement range.

Press **SET** to exit the Language Setting Interface.

Press **▲** or **▼** to choose the former or the next item. Here **▲** can be pressed to choose item 21 below.

下限报警允许
禁止

二十一、下限报警允许

按 **SET** 键进入该项设置状态。

按 **▲** 或 **▼** 键选择：允许 禁止。

当选择允许时，瞬时流量低于下限报警值时仪表就会发出报警信号，但不影响流量显示和累积。

按 **SET** 键退出该项设置状态。

按 **▲** 或 **▼** 键选择下一选项或者上一选项，这里按 **▲** 选择下一选项二十二。

21、Lower limit alarm permit

Press **SET** to enter the Language Setting Interface.

Press **▲** or **▼** to choose: Permit or Prohibit.

If Permit is chosen, the flowmeter will give an alarm signal when the instantaneous flux is lower than the upper limit alarm value. However, the display and accumulation of flux will not be influenced.

Press **SET** to exit the Language Setting Interface.

Press **▲** or **▼** to choose the former or the next item. Here **▲** can be pressed to choose item 22 below.

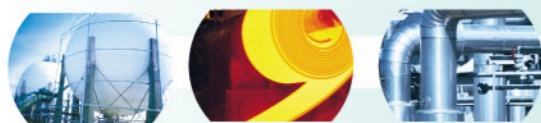

下限报警阈值
010.0%

二十二、下限报警阈值

按 **SET** 键进入该项设置状态。
参照按键说明，修改此项数值到您需要的值。此项设定值就是下限报警值，此值以量程的百分比计算。
按 **SET** 键退出该项设置状态。
按 **▲** 或 **▼** 键选择下一选项或者上一选项，这里按 **▲** 选择下一选项二十三。

22. Lower limit value of alarm threshold

Press **SET** to enter the Language Setting Interface.
With reference to the keystroke instruction, modify the numerical value to your desired value; This set value is the very lower limit value of alarm threshold, and is calculated by percentage of measurement range.
Press **SET** to exit the Language Setting Interface.
Press **▲** or **▼** to choose the former or the next item. Here **▲** can be pressed to choose item 23 below.

仪表通讯地址
0240

二十三、仪表通讯地址

按 **SET** 键进入该项设置状态。
参照按键说明，修改此项数值到您需要的值。此项设定值是4位码地址，用于仪表集控通讯。
按 **SET** 键退出该项设置状态。
按 **▲** 或 **▼** 键选择下一选项或者上一选项，这里按 **▲** 选择下一选项二十四。

23. Instrument communication address

Press **SET** to enter the Language Setting Interface.
With reference to the keystroke instruction, modify the numerical value to your desired value; the set value of this item is a 4-bit code address used for instrument centralized controlling communication.
Press **SET** to exit the Language Setting Interface.
Press **▲** or **▼** to choose the former or the next item. Here **▲** can be pressed to choose item 24 below.

仪表通讯速度
14400

二十四、仪表通讯速度

按 **SET** 键进入该项设置状态。
按 **▲** 或 **▼** 键选择：600，1200，2400，4800，9600，14400。此项值根据接收通讯设备的情况选择合适的速率。
按 **SET** 键退出该项设置状态。
按 **▲** 或 **▼** 键选择下一选项或者上一选项，这里按 **▲** 选择下一选项二十五。

24. Instrument communication speed

Press **SET** to enter the Language Setting Interface.
Press **▲** or **▼** to select: 600, 1200, 2400, 4800, 9600, 14400. The value is to select appropriate rate according to the situation of communication signal receiver.
Press **SET** to exit the Language Setting Interface.
Press **▲** or **▼** to choose the former or the next item. Here **▲** can be pressed to choose item 25 below.

电流零点修正
0.9919

二十五、电流零点修正

此值为出厂校准用，用户不得更改。

按 **SET** 键进入该项设置状态。
参照按键说明，修改此项数值到您需要的值，此项设定值是用于仪表4-20mA输出校准用。在仪表4-20mA输出端测量输出电流，调整此值至输出电流为4mA。
按 **SET** 键退出该项设置状态。
按 **▲** 或 **▼** 键选择下一选项或者上一选项，这里按 **▲** 选择下一选项二十六。

25. Current zero correction

This value is used for calibration before leaving the factory, not allowed to be modified by users.
Press **SET** to enter the Language Setting Interface.
With reference to the keystroke instruction, modify the numerical value to your desired value; this set value is used for outputting calibration of instrument 4-20mA. Measure output current at the output end of the instrument 4-20mA, and adjust the value until the output current is 4mA.
Press **SET** to exit the Language Setting Interface.
Press **▲** or **▼** to choose the former or the next item. Here **▲** can be pressed to choose item 26 below.

电流输出满度修正
0.9937

二十六、电流输出满度修正

此值为出厂校准用，用户不得更改。

按 **SET** 键进入该项设置状态。
参照按键说明，修改此项数值到您需要的值。此项设定值是用于仪表4-20mA输出校准用。在仪表4-20mA输出端测量输出电流，调整此值至输出电流为20mA。
按 **SET** 键退出该项设置状态。
按 **▲** 或 **▼** 键选择下一选项或者上一选项，这里按 **▲** 选择下一选项二十七。

26. Current output full-scale correction

This value is used for calibration before leaving the factory, not allowed to be modified by users.
Press **SET** to enter the Language Setting Interface.
With reference to the keystroke instruction, modify the numerical value to your desired value; this set value is used for outputting calibration of instrument 4-20mA. Measure output current at the output end of the instrument 4-20mA, and adjust the value until the output current is 4mA.
Press **SET** to exit the Language Setting Interface.
Press **▲** or **▼** to choose the former or the next item. Here **▲** can be pressed to choose item 27 below.

电流频率测量输出
10mA/1000Hz

二十七、电流频率测量输出

按 **SET** 键进入该项设置状态。
按 **▲** 或 **▼** 键选择：10mA/1000Hz, 4.16mA/20Hz, 20mA/2000Hz，此项值根据接收电流信号的设备的实际情况选择合适的电流频率。
按 **SET** 键退出该项设置状态。
按 **▲** 或 **▼** 键选择下一选项或者上一选项，这里按 **▲** 选择下一选项二十八。

27. Current frequency measurement output

Press **SET** to enter the Language Setting Interface.
Press **▲** or **▼** to select: 10mA/1000Hz or 4.16mA/20Hz or 20mA/2000Hz, this value is the current frequency selected according to actual situation of current signal receiver.
Press **SET** to exit the Language Setting Interface.
Press **▲** or **▼** to choose the former or the next item. Here **▲** can be pressed to choose item 28 below.



传感器系数
1.7850

二十八、传感器系数

按 **SET** 键进入该项设置状态。
参照按键说明，修改此项数值到您需要的值。此项设定值是用于设定传感器流量系数，其数值可参见仪表铭牌。
按 **SET** 键退出该项设置状态。
按 **▲** 或 **▼** 键选择下一选项或者上一选项，这里按 **▲** 选择下一选项二十九。

28. Sensor coefficient

Press **SET** to enter the Language Setting Interface.
With reference to the keystroke instruction, modify the numerical value to your desired value; this set value is used for setting sensor flow coefficient; see instrument nameplate.
Press **SET** to exit the Language Setting Interface.
Press **▲** or **▼** to choose the former or the next item. Here **▲** can be pressed to choose item 29 below.

仪表标定系数
1.0000

二十九、仪表标定系数

按 **SET** 键进入该项设置状态。
参照按键说明，修改此项数值到您需要的值。此值为显示仪表的标定值，仪表默认值为1。
按 **SET** 键退出该项设置状态。
按 **▲** 或 **▼** 键选择下一选项或者上一选项，这里按 **▲** 选择下一选项三十。

29. Instrument calibration coefficient

Press **SET** to enter the Language Setting Interface.
With reference to the keystroke instruction, modify the numerical value to your desired value; this value shows a calibration value of the instrument, and the instrument default is 1.
Press **SET** to exit the Language Setting Interface.
Press **▲** or **▼** to choose the former or the next item. Here **▲** can be pressed to choose item 30 below.

转换器系数
1.7654

三十、转换器系数

此值为转换器的标定系数，用于仪表出厂标定用，用户不可更改！
按 **▲** 或 **▼** 键选择下一选项或者上一选项，这里按 **▲** 选择下一选项三十一。

30. Converter coefficient

This value is calibration value of the converter used for factory calibration, user must not modify it.
Press **▲** or **▼** to choose the former or the next item. Here **▲** can be pressed to choose item 31 below.

附加系数
1.0000

三十一、附加系数

按 **SET** 键进入该项设置状态。
参照按键说明，修改此项数值到您需要的值。此值为显示仪表的内部参数，仪表默认值为1。
按 **SET** 键退出该项设置状态。
按 **▲** 或 **▼** 键选择下一选项或者上一选项，这里按 **▲** 选择下一选项三十二。

31. Additional coefficient

Press **SET** to enter the Language Setting Interface.
With reference to the keystroke instruction, modify the numerical value to your desired value; the value shows internal parameter of the instrument, the instrument default is 1.
Press **SET** to exit the Language Setting Interface.
Press **▲** or **▼** to choose the former or the next item. Here **▲** can be pressed to choose item 32 below.

积算总量清零
00000000

三十二、积算总量清零

按 **SET** 键进入该项设置状态。
参照按键说明，修改此项数值为：77770000。若此值被修改为77770000，累积流量将被置为0。
按 **SET** 键退出该项设置状态。
按 **▲** 或 **▼** 键选择下一选项或者上一选项，这里按 **▲** 选择下一选项三十三。

32. Integrating gross and reset

Press **SET** to enter the Language Setting Interface.
Change the figure to 77770000 based on button specifications. If the figure is modified as 77770000, the cumulative flow is set as 0.
Press **SET** to exit the Language Setting Interface.
Press **▲** or **▼** to choose the former or the next item. Here **▲** can be pressed to choose item 33 below.

预置正向累积总量
00000000000000

三十三、预置正向累积总量

按 **SET** 键进入该项设置状态。
参照按键说明，修改此项数值到您需要的值。此值设置后正向总量将增加您设置的量。
按 **SET** 键退出该项设置状态。
按 **▲** 或 **▼** 键选择下一选项或者上一选项，这里按 **▲** 选择下一选项三十四。

33. Preset positive total accumulation

Press **SET** to enter the Language Setting Interface.
With reference to the keystroke instruction, modify the numerical value to your desired value; after the value is set, the positive total accumulation will increase your set volume.
Press **SET** to exit the Language Setting Interface.
Press **▲** or **▼** to choose the former or the next item. Here **▲** can be pressed to choose item 34 below.



预置反向累积总量
000000000000

三十四、预置反向累积总量

按 **SET** 键进入该项设置状态。
参照按键说明，修改此项数值到您需要的值。此值设置后反向总量将增加您设置的量。
按 **SET** 键退出该项设置状态。
按 **▲** 或 **▼** 键选择下一选项或者上一选项，这里按 **▲** 选择下一选项三十五。
34、Preset reverses total accumulation
Press **SET** to enter the Language Setting Interface.
With reference to the keystroke instruction, modify the numerical value to your desired value; after the value is set, the reverse total accumulation will increase your set volume.
Press **SET** to exit the Language Setting Interface.
Press **▲** or **▼** to choose the former or the next item. Here **▲** can be pressed to choose item 35 below.

电导率转换系数
0048.830

三十五、电导率转换系数

仪表内部参数不得修改。
按 **▲** 或 **▼** 键选择下一选项或者上一选项，这里按 **▼** 选择下一选项三十六。
35、Conductivity conversion coefficient
Instrument internal parameter must not be modified.
Press **▲** or **▼** to choose the former or the next item. Here **▲** can be pressed to choose item 36 below.

满管时电导测量值
002000.0

三十六、满管时电导测量值

仪表内部参数不得修改。
按 **▲** 或 **▼** 键选择下一选项或者上一选项，这里按 **▼** 选择下一选项三十七。
36、Full pipe conductance measurement value
Instrument internal parameter must not be modified.
Press **▲** or **▼** to choose the former or the next item. Here **▲** can be pressed to choose item 37 below.

流量零点自动修正
+0000.000

三十七、流量零点自动修正

仪表内部参数不得修改。
按 **▲** 或 **▼** 键选择下一选项或者上一选项，这里按 **▼** 选择下一选项三十八。
37、Flow zero point automatic correction
Instrument internal parameter must not be modified.
Press **▲** or **▼** to choose the former or the next item. Here **▲** can be pressed to choose item 38 below.

励磁测量允许
禁止

三十八、励磁测量允许

仪表内部参数不得修改。
按 **▲** 或 **▼** 键选择下一选项或者上一选项，这里按 **▼** 选择下一选项三十九。
38、Excitation measurement permission
Instrument internal parameter must not be modified.
Press **▲** or **▼** to choose the former or the next item. Here **▲** can be pressed to choose item 39 below.

选择励磁方式
方式3

三十九、选择励磁方式

仪表内部参数不得修改。
按 **▲** 或 **▼** 键选择下一选项或者上一选项，这里按 **▼** 选择下一选项四十。
39、Selecting excitation ways
Instrument internal parameter must not be modified.
Press **▲** or **▼** to choose the former or the next item. Here **▼** can be pressed to choose item 40 below.

转换器编码
00000000

四十、转换器编码

仪表内部参数不得修改。
按 **▲** 或 **▼** 键选择下一选项或者上一选项，这里按 **▼** 选择下一选项四十一。
40、Converter codes
Instrument internal parameter must not be modified.
Press **▲** or **▼** to choose the former or the next item. Here **▼** can be pressed to choose item 41 below.

一级密码
0000

四十一、一级密码

仪表内部参数不得修改。
按 **▲** 或 **▼** 键选择下一选项或者上一选项，这里按 **▲** 选择下一选项四十二。
41、Primary password
Instrument internal parameter must not be modified.
Press **▲** or **▼** to choose the former or the next item. Here **▼** can be pressed to choose item 42 below.

二级密码
0000

四十二、二级密码

仪表内部参数不得修改。
按 **▲** 或 **▼** 键选择下一选项或者上一选项，这里按 **▲** 选择下一选项四十三。
42、Secondary password
Instrument internal parameter must not be modified.
Press **▲** or **▼** to choose the former or the next item. Here **▼** can be pressed to choose item 43 below.

三级密码
0000

四十三、三级密码

仪表内部参数不得修改。
按 **▲** 或 **▼** 键选择下一选项或者上一选项，这里按 **▲** 选择下一选项四十四。
43、Three-level password
Instrument internal parameter must not be modified.
Press **▲** or **▼** to choose the former or the next item. Here **▼** can be pressed to choose item 44 below.



四级密码
0000

四十四、四级密码

仪表内部参数不得修改。

按 ▲ 或 ▼ 键选择下一选项或者上一选项，这里按 ▲ 选择下一选项四十五。

44、Four-level password

Instrument internal parameter must not be modified.

Press ▲ or ▼ to choose the former or the next item. Here ▲ can be pressed to choose item 45 below.

五级密码
0000

四十五、五级密码

仪表内部参数不得修改。

按 ▲ 或 ▼ 键选择下一选项或者上一选项，这里按 ▲ 选择下一选项四十六。

45、Five-level password

Instrument internal parameter must not be modified.

Press ▲ or ▼ to choose the former or the next item. Here ▲ can be pressed to choose item 46 below.

流速斜率限制
30%

四十六、流速斜率限制。

(30%) 仪表内部参数不得修改。

按 ▲ 或 ▼ 键选择下一选项或者上一选项，这里按 ▲ 选择下一选项四十七。

46、Velocity slope restrictions

(30%) Instrument internal parameter must not be modified.

Press ▲ or ▼ to choose the former or the next item. Here ▲ can be pressed to choose item 47 below.

流速斜率限制时间
10S

四十七、流速斜率限制时间

(10S) 仪表内部参数不得修改。

按 ▲ 或 ▼ 键选择下一选项或者上一选项，这里按 ▲ 选择下一选项四十八。

47、Velocity slope limited time

(10S) Instrument internal parameter must not be modified.

Press ▲ or ▼ to choose the former or the next item. Here ▲ can be pressed to choose item 48 below.

输入方式选择
累积清零

四十八、输入方式选择

(累积清零) 仪表内部参数不得修改。

按 ▲ 或 ▼ 键选择下一选项或者上一选项，这里按 ▲ 选择下一选项四十九。

48、Input way selection

(Cumulative clear) Instrument internal parameter must not be modified.

Press ▲ or ▼ to choose the former or the next item. Here ▲ can be pressed to choose item 49 below.

非线性校正允许
允许

四十九、非线性校正允许

(禁止) 仪表内部参数不得修改。

按 ▲ 或 ▼ 键选择下一选项或者上一选项，这里按 ▲ 选择下一选项五十。

49、Non-linear correction permission

(Prohibited) Instrument internal parameter must not be modified.

Press ▲ or ▼ to choose the former or the next item. Here ▲ can be pressed to choose item 50 below.

非线性校正系数1
001.000%,01.000

五十、非线性校正系数1

(1%, 1) 仪表内部参数不得修改。

按 ▲ 或 ▼ 键选择下一选项或者上一选项，这里按 ▲ 选择下一选项五十一。

50、Non-linear correction coefficient 1

(1%, 1) Instrument internal parameter must not be modified.

Press ▲ or ▼ to choose the former or the next item. Here ▲ can be pressed to choose item 51 below.

非线性校正系数2
005.000%,01.000

五十一、非线性校正系数2

(5%, 1) 仪表内部参数不得修改。

按 ▲ 或 ▼ 键选择下一选项或者上一选项，这里按 ▲ 选择下一选项五十二。

51、Non-linear correction coefficient 2

(5%, 1) Instrument internal parameter must not be modified.

Press ▲ or ▼ to choose the former or the next item. Here ▲ can be pressed to choose item 52 below.

非线性校正系数3
010.000%,01.000

五十二、非线性校正系数3

(10%, 1) 仪表内部参数不得修改。

按 ▲ 或 ▼ 键选择下一选项或者上一选项，这里按 ▲ 选择下一选项五十三。

52、Non-linear correction coefficient 3

(10%, 1) Instrument internal parameter must not be modified.

Press ▲ or ▼ to choose the former or the next item. Here ▲ can be pressed to choose item 53 below.

非线性校正系数4
015.000%,01.000

五十三、非线性校正系数4

(15%, 1) 仪表内部参数不得修改。

按 ▲ 或 ▼ 键选择下一选项或者上一选项，这里按 ▲ 选择下一选项五十四。

53、Non-linear correction coefficient 4

(15%, 1) Instrument internal parameter must not be modified.

Press ▲ or ▼ to choose the former or the next item. Here ▲ can be pressed to choose item 54 below.



非线性校正系数5
020.000%,01.000

五十四、非线性校正系数5

(20%, 1) 仪表内部参数不得修改。

按 **▲** 或 **▼** 键选择下一选项或者上一选项，这里按 **▲** 选择下一选项五十五。

54、Non-linear correction coefficient 4

(20%, 1) Instrument internal parameter must not be modified.

Press **▲** or **▼** to choose the former or the next item. Here **▲** can be pressed to choose item 55 below.

流体密度
0001.00001/m³

五十五、流体密度

按 **SET** 键进入该项设置状态

参照按键说明，修改此项数值到您需要的值。

此值是被测介质流体密度，但你选择质量流量时设置。

按 **SET** 键退出该项设置状态

按 **▲** 或 **▼** 键选择下一选项或者上一选项，这里按 **▲** 选择下一选项五十六。

55、Fluid density

Press **SET** to enter the Language Setting Interface.

With reference to the keystroke instruction, modify the numerical value to your desired value.

This value is fluid density of the measured medium, and it is set when you select mass flow.

Press **SET** to exit the Language Setting Interface.

Press **▲** or **▼** to choose the former or the next item. Here **▲** can be pressed to choose item 56 below.

五十六、仪表参数重置

(禁止) 仪表内部参数不得修改)

56、Instrument parameter reset

(Prohibited) Instrument internal parameter must not be modified.

按 **←** + **SET** 退出该项仪表设置状态，仪表设置结束。

Press **←** and **SET** keys to exit the instrument setting status, and the instrument setting is ended.

流量计型号说明 Flowmeter model description

名称 Name	规格代码 Specification code	说明 Explanation
仪表种类 Instrument type		智能电磁流量计 Intelligent electromagnetic flowmeter
通径代码 Diameter code	xxx	例:100表示DN100 For example: 100 represents DN100
电极形式 Electrode form	1	标准固定式 Standard stationary type
电极材料 Electrode material	0	不锈钢(316L) Stainless steel (316L)
	1	铂Pt Platinum Pt
	2	哈氏B(HB) Hastelloy B (HB)
	3	钽Ta Tantalum Ta
	4	钛Ti Titanium Ti
内衬材料 Lining material	5	哈氏C(HC) Hastelloy C (HC)
	3	氯丁橡胶 Chloroprene rubber
	4	聚氨酯橡胶 Polyurethane rubber
额定压力(MPa) Rated pressure	5	F4(PTEE)聚四氟乙烯 F4 (PTEE) polyfluortetraethylene
	6	F46(FEP)聚全氟代乙丙烯 F46 (FEP) polyperfluoroethylene-propylene
	4.0	DN10- 80
	1.6	DN100-150
工作温度 Operating temperature	1.0	DN200-1000
	0.6	DN1100-2000
	0.25	DN2200
接地 Grounding	E	<60℃
防护等级 Grade of protection	H	<120℃
	0	内置接地电极 Built-in grounding electrode
转换器型式 Converter type	0	IP65
	1	IP68
外壳材料 Case material	0	一体式 Integral type
	1	分体式 Split type
表体法兰 Instrument flange	-0	碳钢 Carbon steel
	1	不锈钢 Stainless steel
安装时法兰 Installing timing flange	0	碳钢 Carbon steel
	1	不锈钢 Stainless steel
供电电源 Power supply source	0	不带 Without
	1	带 With
仪表量程 Instrument range	0	220VAC
	1	24VDC
	(xxx)	例: (200)表示20mA对应的最大 流量为200m ³ /h For example: (200) represents maximum flux corresponding to 20mA 流量为200m ³ /h

举例: 100-103-1.6E00-0010

说明: 智能电磁流量计, DN100, 固定式不锈钢电极, 氯丁橡胶内衬, 额定压力1.6Mpa, 温度≤60℃, IP65, 一体式, 外壳材料和法兰为碳钢, 带安装时法兰(包括螺栓螺母), 220伏交流供电。

For example: 100-103-1.6E00-0010

Explanation: Intelligent electromagnetic flowmeter DN100 has a fixed stainless steel electrode and Chloroprene rubber lining with a rated pressure of 1.6 Mpa and a temperature less than or equal to 60 degrees centigrade, IP65, it is an integral type, case material and flange are carbon steel, with installed matched flange (including bolt and nut) and 220 V AC power supply is applicable.



一体式流量计外形尺寸

Outline dimension of integral flowmeter:

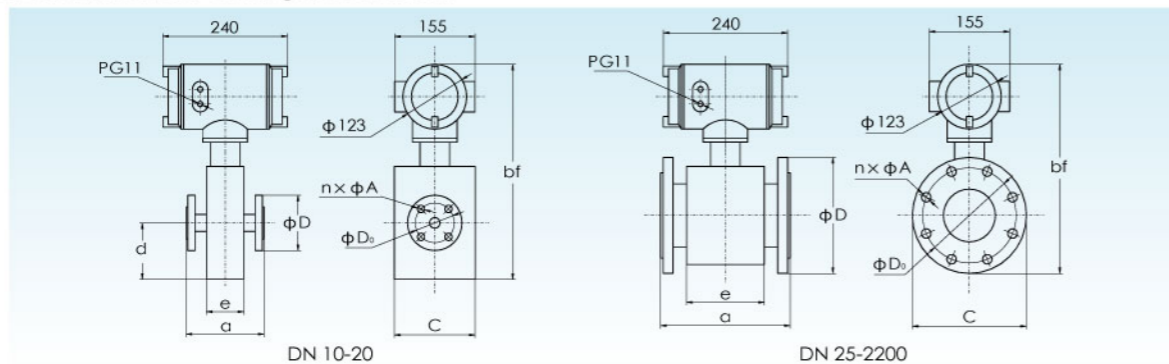

DN	额定压力 Rated pressure (MPa)	仪表外形尺寸(mm) Instrument outline dimension					法兰连接尺寸(mm) Flange connecting size		
		a	bf	c	d	e	D	D ₀	n x A
10	4.0	150	408	156	107	72	90	60	4 x 14
15		150	408	156	107	72	95	65	4 x 14
20		150	408	156	107	72	105	75	4 x 14
25		150	303	115		78	115	85	4 x 14
32		150	319	140		78	140	100	4 x 18
40		150	332	150		93	150	110	4 x 18
50		200	346	165		109	165	125	4 x 18
65		200	367	185		105	185	145	8 x 18
80	200	382	200		101	200	160	8 x 18	
100	1.6	250	397	220		150	220	180	8 x 18
125		250	429	250		150	250	210	8 x 18
150	300	459	285		180	285	240	8 x 22	
200	1.0	350	517	340		222	340	295	8 x 22
250		400	570	395		254	395	350	12 x 22
300		500	617	445		316	445	400	12 x 22
350		500	668	505		305	505	460	16 x 22
400		600	723	565		380	565	515	16 x 26
450		600	773	615		380	615	565	20 x 26
500		600	825	670		400	670	620	20 x 26
600		600	930	780		456	780	725	20 x 30
700		700	1038	895		545	895	840	24 x 30
800		800	1148	1015		580	1015	950	24 x 33
900	900	1248	1115		690	1115	1050	28 x 33	
1000	1000	1355	1230		750	1230	1160	28 x 36	
1200	0.6	1200	1674	1405		1206	1405	1340	32 x 33
1400		1400	1874	1630		1406	1630	1560	36 x 36
1600		1600	2084	1830		1606	1830	1760	40 x 36
1800		1800	2304	2045		1806	2045	1970	44 x 39
2000		2000	2504	2265		2006	2265	2180	48 x 42
2200		2200	2704	2405		2206	2405	2315	52 x 45

电磁流量计的选型最好由熟悉现场工艺条件的技术人员进行按选型资料中可测流量范围表选择合适的口径材料选择最好由熟悉现场工艺条件的最终用户确定

The selection of the electromagnetic flowmeter is preferably performed by a technician who is familiar with on-site technological conditions, the technician shall select proper aperture material according to the measurable range table in the type selection material, and the selection is preferably confirmed by an end user who is familiar with the on-site technological conditions.

选择流量计类型 Selecting flowmeter type

一体型和分离型 Integral type and split type

一体型和分离型各有优点，选择的基本原则如下：分离型一般用于现场维护及调试时读数不方便或经常浸泡在水中和其它功能的场合。它也用于较恶劣的应用场合，如：高温流体、有振动源处及易爆环境中。大多数场合一体型和分离型都能满足使用要求。

Both integral type and split type have their own advantages, and basic principals for selection are as follows: the split type is usually used in situations inconvenient for one-site maintenance and numerical reading when debugging is difficult or the flowmeter is often immersed in water and with other functions. It is also used in poor application situations, such as high temperature fluid, a position with vibration source and explosive environment. In most cases, both the integral type and the split type can meet use requirements.

一般型和防爆型 General type and explosion-proof type

用户应根据流量计使用环境确定选择一般型还是防爆型。

Users shall confirm to select a general type or an explosion-proof type according to application environment of the flowmeter.

传感器的口径与连接的工艺管道口径

The diameter of the sensor and that of technological pipeline.

一般情况，考虑安装方便，不要选择异径管。但前提是流量计管内的使用流速应在0.3m/s~10m/s范围内。这种选择常适用于新设计的工程，在选择流速时既要考虑现在的工作情况，又要考虑将来设备满负荷运转时的情况。流量、流速与口径三者关系可查阅曲线图。但有时也选择传感器的口径与连接的工艺管道口径不相同。如：

- 1、管道内的流速偏低，工艺流量又能较稳定，为满足仪表对流量范围的要求，在流量计处局部提高流速，选择传感器口径小于工艺管道口径，在传感器前后加接异径管。
- 2、对于大口径电磁流量计，口径越大，价格越高，对管道内流速偏低，工艺参数稳定的情况，可选用口径较小的流量计，这不仅使流量计运行在较好的工作状态下，同时降低投资成本。

Generally, it's suggested not to select reducing pipe for the sake of convenient installation, provided that the use flow in the flowmeter pipe shall be within the range of 0.3m/s~10m/s. This kind of selection is usually applicable to a newly-designed project for which current work situation is not only considered when choosing a flow speed, but also a situation of running at full load of the device in the future shall also be considered. For the relationships among the flux, velocity and diameter, see curve graph. However, sometimes we also choose a sensor with a different diameter with the connected technological pipeline diameter, for example:

- 1、The flow speed in the pipeline is low and the process flow is stable, in order to meet the demand of instrument to flow range, to improve flow speed at local of the flowmeter, select a sensor with smaller diameter than the diameter of the technological pipeline, and additionally connect a reducing pipe at front and rear part of the sensor.
- 2、In terms of large diameter electromagnetic flowmeter, the diameter is larger, the price is higher, as for the situations with low flow speed in the pipeline and stable technological parameter, small diameter flowmeter may be chosen, this not only runs the flowmeter under good working state, but also reduces investment cost at the same time.



直管段长度 Length of straight pipe segment

为了保证电磁流量计高测量精度所需的上游管路条件。根据上述标准和管路条件测定数据，推荐如下图所示的管路条件。

Upstream pipeline condition desired in guaranteeing high measurement precision. To measure data according to above standard and pipeline condition, WE company recommends pipeline condition shown in following figure.

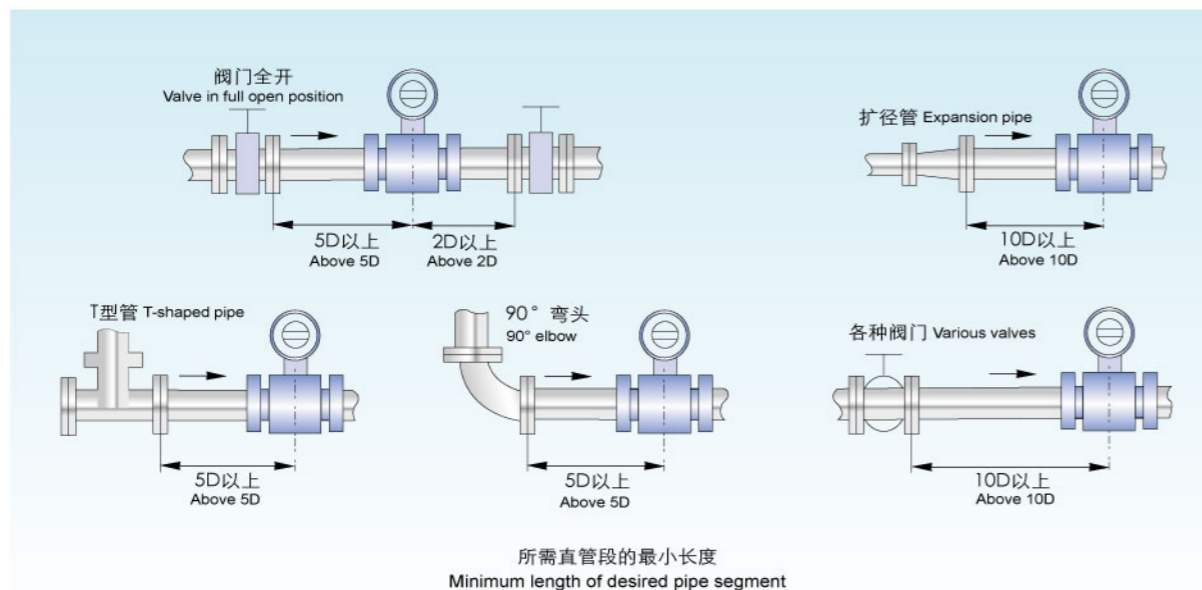

加装异径管应注意问题

Notes for additionally installing a reducing pipe

异径管锥角的选择 Selection of a reducing pipe cone angle

为了在安装异径管后不过多影响流场的分布，不影响电磁流量计的精度，可把异径管视为直管段的一部分。要求异径管的中心锥角 α 不大于 15° ，越小越好。

For not mapping distribution of flow field after installing the reducing pipe, and not influencing precision of the electromagnetic flowmeter, the reducing pipe can be regarded as one part of the straight pipe segment. The central cone angle α of the reducing angle shall be no more than 15° degrees, and the smaller the better.

安装异径管会产生压力损失

总的压力损失由三部分组成：

渐缩管中的压力损失 $\Delta P1 = \rho/2\xi1V2^2$

渐扩管中的压力损失 $\Delta P3 = \rho/2\xi3V2^2$

传感器测量管中的压力损失 $\Delta P2 = \rho/2\xi2V2^2$

总的压力损失为

$\Delta P = 0.01 (\Delta P1 + \Delta P2 + \Delta P3)$ (mbar)

式中 ρ 是介质密度，单位是 kg/m^3

$\xi1\xi3$ 是分别为渐缩管的，渐扩管的与雷诺数有关的系数

$\xi2=0.02$ 是传感器测量管的系数

$V1V2$ 分别是工艺管道、传感器测量管中的流速，单位为 m/s

Installing a reducing pipe will cause pressure loss

Total pressure loss composes pressure loss in the gradual contraction pipe by three parts:

Pressure loss of a Gradual contraction pipe $\Delta P1 = \rho/2\xi1V2^2$

Pressure loss of a gradual enlargement pipe $\Delta P3 = \rho/2\xi3V2^2$

Pressure loss in the sensor measurement pipe $\Delta P2 = \rho/2\xi2V2^2$

The total pressure loss is: $\Delta P = 0.01 (\Delta P1 + \Delta P2 + \Delta P3)$ (mbar)

In the formula, ρ is a medium density, whose unit is kg/m^3

$\xi1\xi3$ are respectively coefficients related with the Reynolds number

$\xi2=0.02$ it is a Coefficient of Transducer Measuring tube

$V1V2$ are respectively flow speeds in the technological pipeline and sensor measurement pipe, whose unit is m/s .

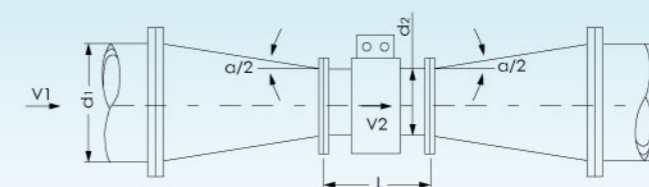

例如： $\alpha=8^\circ$ 时 ζ 的值 E.g. the value of ζ when $\alpha=8^\circ$

d_1/d_2	1.2	1.3	1.4	1.5	1.6	1.7	1.8	1.9	2.0
ζ_1	0.018	0.023	0.0255	0.028	0.03	0.0308	0.0315	0.0323	0.0332
ζ_3	0.01	0.02	0.07	0.15	0.26	0.43	0.64	0.9	1.25

安装方向 Installation direction

在安装电磁流量计时，一般情况下，水平安装时电极的轴线应近似水平；如果电极的轴线与地面垂直的话，处于上面的电极附近容易集结气泡，阻挡液体与之接触而处于下面的电极容易被泥浆覆盖。应将转换器安装在管路的上面，防止水进入转换器。

When installing an electromagnetic flowmeter, generally speaking, the axis line of the electrode shall be approximate level in horizontal installation; if the axis line of the electrode is perpendicular to the ground, bubbles will be easily collected near the electrode located on the upper side, the electrode located at lower side and stopping the liquid contacting with the same is covered by slurry. The converter shall be installed above the pipeline to prevent water from entering the converter.

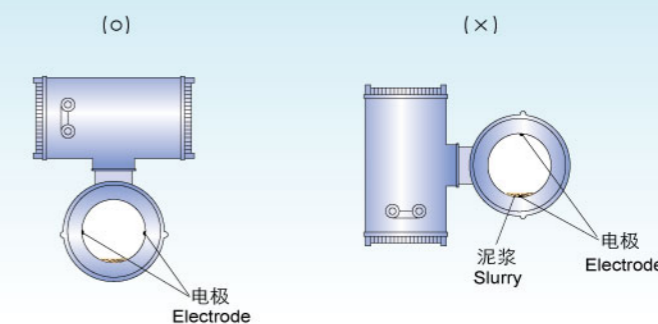

渐缩管

Gradual contraction pipe

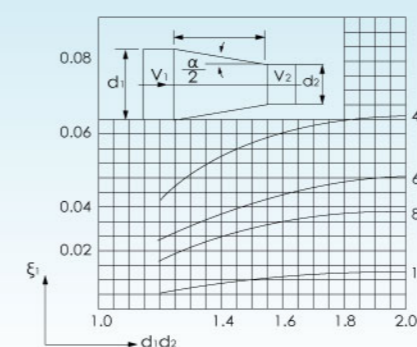

渐扩管

Gradual enlargement pipe

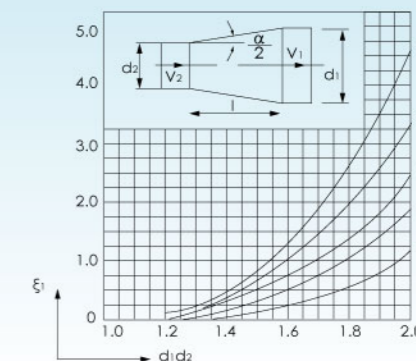

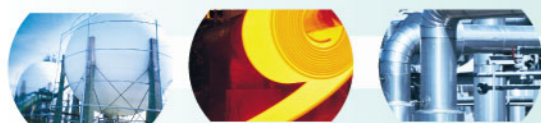

电磁流量计必须在满管条件下工作——不满管或空管的情况下，流量计都不能正常工作。
Electromagnetic flowmeter must work in full pipe conditions; that is to say, the flowmeter cannot normally work in part-filled pipe or empty pipe conditions.

液体流动的正方向一般应与传感器上的箭头方向一致。流量计附近必须有足够的安装维修空间防止流量计受振动。在安装流量计时，流量计两边应有支撑管线的支座。防止由于管路振动、冲击及收缩而关系到应力。重污染液体，应考虑在旁路上安装流量计。

The positive direction in which fluid flows is generally in the same direction as the arrows in the sensor. There must be an enough installation and maintenance space close to the flowmeter to prevent the flowmeter from being vibrated. During installation of the flowmeter, supports for supporting pipelines should be provided on the two sides of the flowmeter. Stress is prevented from being affected because of pipeline vibration, impact and shrinkage. For heavy polluted fluid, a consideration that a flowmeter is installed on the pipeline should be given.

流量计配管 Flowmeter piping

管路的不对中或倾斜是管路法兰跳动和断裂的原因。

- (1) 在流量计安装时，应先校正管路的不对中或倾斜，以及两法兰之间的安装距离偏差。
- (2) 在安装的流量计管道路一般有异物（如焊渣和大屑）。在安装流量计之前应把这些杂物冲掉。

Misalignment or inclination of pipeline is a reason why the pipeline flange bounces and breaks.

- (1) During installation of flowmeter, misalignment or inclination of pipeline, and installation distance deviation between two flanges should be corrected first.
- (2) During installation of flowmeter, generally there are some foreign matters (e.g., welding slag and scraps) within pipeline road. Prior to installing the flowmeter, these impurities should be washed away.

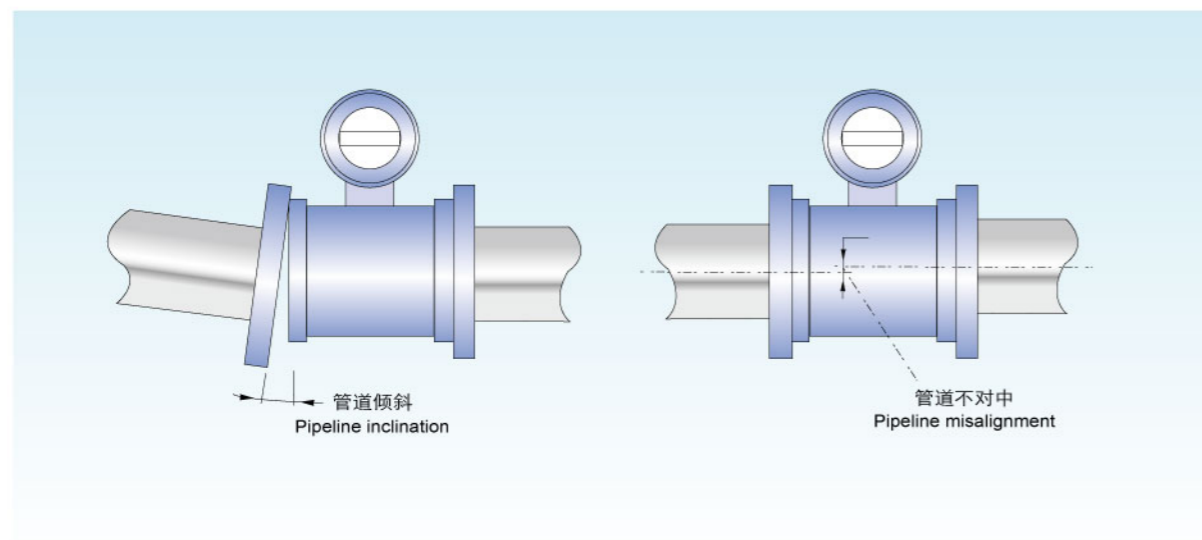

液体电导率 Conductivity of fluids

不要把电磁流量计安装在液体电导率极不均匀的地方。尤其在仪表上游有化学物质注入的情况下，极易导致电导率的不均匀性，从而对流量计测量产生严重干扰。在这种情况下，我们推荐在仪表下游注入化学物质。如果必须从仪表上游注入化学物质，则必须装上足够长的直管段，以保证液体充分混合均匀。

Electromagnetic flowmeter cannot be installed where the conductivity of fluids is very uneven. In particular when chemicals are injected from the upstream of the instrument, it is very easy to cause unevenness of conductivity, thereby seriously interfering the measurement of flowmeter. In this case, we recommend that chemicals should be injected from the downstream of the instrument. If chemicals must be injected from the upstream of the instrument, a straight pipe section which is long enough must be installed to ensure that fluids are mixed well.

液体密封剂 Liquid sealant

使用液体密封剂时应注意：

不要让它覆盖在电极和接地环表面，因为这样会影响对流量的测量。

The following points should be mentioned during using fluid sealant:

Don't let it cover the surfaces of electrode and grounding ring because this will influence the measurement of fluid flow.

采用节流阀和旁通阀 Adopting throttle valves and bypass valves

为了方便维修、调零，建议采用材料节流阀和旁通阀。

For convenient maintenance and zero setting, throttle valves and bypass valves are suggested to adopt.

确保在流量计中无气泡 Ensuring no bubble in flowmeter

管路设计应确保液体中不会分离出气泡。一般流量计应安装在阀的上游。因为由于阀的作用使管道中的压力降低，从而产生气泡。

Pipeline design should ensure that no bubble can be separated from fluid. Generally, the flowmeter should be installed on the upstream of the valve, because the pressure in the pipeline is reduced under the action of the valve, thereby producing bubble.

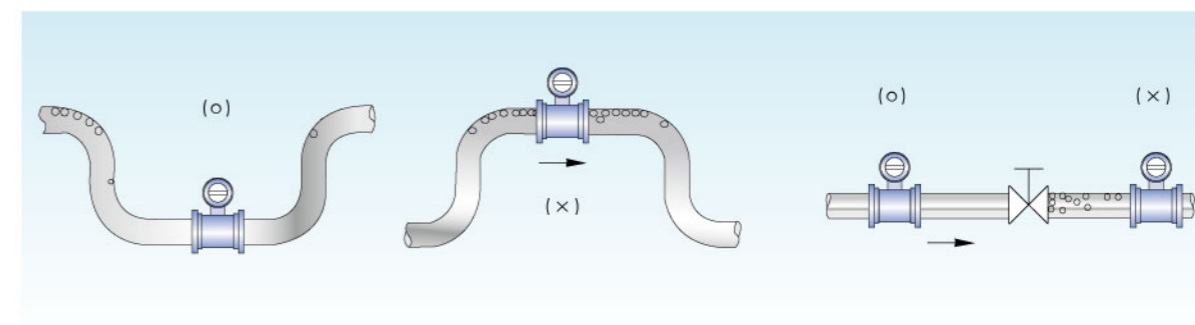

电极材料的选择 Selection of electrode materials

电极材料的选择应根据被测介质的腐蚀性，由熟悉现场条件的用户负责选定。一般情况下，电极材料的腐蚀性要比管道材料高一个等级。对一般介质，可查阅有关防腐手册，对混酸等成分复杂的介质，应做挂片试验。

Electrode materials should be selected according to corrosivity of measured medium, and selected by users familiar with site conditions. In general, the corrosion resistance of electrode material is higher than that of pipeline material by one grade. For ordinary media, please consult related anti-corrosion manuals. For media having complex components such as mixed acid, coupon tests should be done.

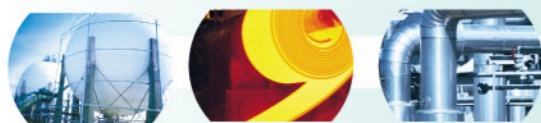

电极材料性能 (仅供参考) Properties of electrode material (for reference only)

电极材料 Electrode material	测量材料性能 (仅供参考) Properties of measured material (for reference only)	耐腐蚀性能 Corrosion resistance
不锈钢SUS 316L Stainless steelSUS 316L	生活及工业用水和污水 Domestic and industrial water and sewage	不能用于无机酸、有机酸、氯化物 Not for use in inorganic acid, organic acid, chloride
哈氏合金C Hastelloy alloy C	海水、硫酸钠 Seawater, sodium sulfate	不适用于氯化物、硫酸、适用于摩擦性流体 Not suitable for chloride, sulfuric acid, suitable for frictional fluid
钽 Tantalum	盐酸、王水 Hydrochloric acid, aqua regia	几乎适用于所有的化学物质, 但对氢氟酸、发烟硝酸尚有些问题 Almost suitable for all chemicals, but there are also some problems for hydrofluoric acid and fuming nitric acid
钛 Titanium	乙酸、氯化钠 Acetic acid, sodium chloride	适用于氯化钠、硫化物、碱液、但不能用于盐酸、硫酸和硝酸 Suitable for sodium chloride, sulfide, alkali liquor, but not suitable for hydrochloric acid, sulfuric acid and nitric acid
铂-铱合金 Platinum-iridium alloy	氢氧化钠、浓硫酸 Sodium hydroxide, concentrated sulfuric acid	几乎适用于所有化学物质, 但不适用于王水和铵盐 Almost suitable for all chemicals, but not suitable for aqua regia and ammonium salt
碳化钨 Tungsten Carbide	纸浆 Paper pulp	能抗固体颗粒干扰, 不能用于无机酸、有机酸、氯化物 Solid particles anti-interference, not for use in inorganic acid, organic acid, chloride

接地环材料的选择 Selection of grounding ring material

接地环材料可以与电极材料相同, 一般可选与管道材料耐腐蚀性相同的材料。

Grounding ring material can be the same as the electrode material; generally material with the same corrosion resistance as the pipeline material is selectable.

衬里材料的选择 Selection of lining material

衬里材料应根据被测液体种类和工作温度来选择。PFA是一种氟化塑料, 具有良好的耐强酸、强碱的腐蚀性, 同时具有良好的耐高温性, 高温下不变形, 不降低绝缘阻抗。99.9%高纯度氧化铝用于制作陶瓷衬里, 它使得仪表能够高精度测量流量, 因为与传统的高分子材料相比, 陶瓷不会产生高温、高压变形, 并且具有良好的耐磨性。

Lining material should be selected according to the type and working temperature of measured fluid. PFA is a fluorinated plastic, has good corrosion resistance to strong acid, strong alkali, at the same time has good high temperature resistance, does not deform at high temperature. Insulation resistance is not reduced. 99.9% high purity alumina is used for making ceramic lining so that the instrument can measure the flow with high precision. In comparison with traditional high polymer material, ceramics cannot create high temperature, high pressure deformation, and have good wear resistance.

电磁流量计衬里主要性能和适用范围 (仅供参考)

衬里材料	主要性能	衬里适用范围	可测介质举例	注意事项	
(特氟隆)	PTFE	1.化学稳定性优良, 但氟元素和熔融状态的金属钠对其制品有一定腐蚀性。 2.能耐盐酸、硫酸、和王水, 并且有机溶剂对它几乎不起作用。 3.耐磨性和粘接性能差。 4.电绝缘性能优异, 但耐电晕性较差。	1.流量计长期使用温度-10~+120℃。 2.能用于测量大多数强酸、强碱、强氧化剂等强腐蚀性介质; 但不适用于KOH, 硝酸、氢氟酸等。 3.卫生类介质。	1.盐酸、硫酸、王水。 2.其它多数强酸、强碱和氧化剂。 3.不适用于带固体颗粒的介质。	1.不适用于KOH、硝酸、氢氟酸。 2.一般不用于测量电解液, 如: 从电解槽流出的NaCl溶液 3.不适用于带固体颗粒的介质。
	FEP	1.其化学稳定性、电绝缘性、润滑性、不粘性和不燃性与PTFE (F4) 相仿, 但FEP材料强度、耐老化性、耐温性能和低温柔韧性优于PTFE。 2.与金属粘接性好, 耐磨性好于PTFE。 3.具有较好的抗撕裂性能。	1.流量计长期使用温度-40~+80℃。 2.能用于测量大多数强酸、强碱、强氧化剂等强腐蚀性介质; 但不适用于KOH, 硝酸、氢氟酸等。 3.卫生类介质。	1.盐酸、硫酸、王水 2.其它多数强酸、强碱和氧化剂。 3.带少量细小颗粒的介质。	1.不适用于KOH、硝酸、氢氟酸。 2.一般不用于测量电解液, 如: 从电解槽流出的NaCl溶液。
	PFA	1.其化学稳定性、电绝缘性、润滑性、不粘性和不燃性与FEP (F46) 相仿, 但PFA材料强度、耐老化性、耐温性能优于PTFE、FEP。 2.与金属粘接性好, 耐磨性好于PTFE、FEP。 3.低烟、难燃、耐高温, 高温机械强度比PTFE高2倍	1.流量计长期使用温度-40~+160℃。 2.能用于测量大多数强酸、强碱、强氧化剂等强腐蚀性介质; 但不适用于KOH, 硝酸、氢氟酸等。 3.卫生类介质。	1.盐酸、硫酸、王水 2.其它多数强酸、强碱和氧化剂。 3.带少量细小颗粒的介质。 4.啤酒、皂化液化气等。	1.不适用于KOH、硝酸、氢氟酸。 2.一般不用于测量泥浆、煤浆、矿浆。
聚氨酯橡胶	1.有极好的耐磨性能, 良好的耐油性。 2.强度高、耐撕裂性好, 但耐酸、耐碱性能较差。 3.耐热性不好, 一般为60℃	1.一般长期使用温度-10~+60℃。 2.耐磨性好, 适用于含固体颗粒的液体。 3.不能用于测量含有有机溶剂的水。	1.中性强磨损的矿浆、煤浆、泥浆。 2.生活用水、工业用水、污水、海水。	1.液体温度范围0~40℃。 2.一般不用于测量混有有机溶剂的介质。	
氯丁橡胶	1.有良好的弹性和抗撕裂性, 具有一定耐油性。 2.抗老化性较差, 其脆性温度为-28℃。 3.耐磨性能不如聚氨酯橡胶。 4.耐一般性低浓度酸、碱、盐介质的腐蚀, 不耐氧化性介质的腐蚀。	1.长期使用温度-10~+80℃。 2.由于其中含有防老剂D, 略有污染性。 3.适用于一般低浓度酸、碱、盐介质及污水测量。	1.一般水、污水 2.泥浆、矿浆	1.不能用于测量食品。 2.不适用于测量强酸、强碱、强氧化性介质。	
陶瓷	1.强度高、高温、高压下不变形。 2.独特的钎氧化铝金属陶瓷电极。 3.具有较好的抗泥浆噪声能力, 适用于渗透性流体。 4.良好的耐磨性, 其耐磨性是聚氨酯的10倍。	1.适合于高温高压流体、粘性流体、腐蚀性流体。 2.渗透性流体, 含固体颗粒的浆液。	1.含硬固体的浆液、腐蚀性流体、粘性流体、高温高压流体。 2.硫酸铝、25%的次氯酸钠、硝酸等。	1.不适用于氢氟酸、硝酸、王水、NaOH、70%浓度的硫酸。 2.不能用于硫酸铜、碳酸氢钠等部分盐类物质。	

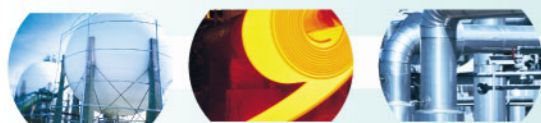

Main properties and application range of electromagnetic flowmeter lining (for reference only)

Lining material		Main Properties	Application Range of Lining	Examples of Measurable Media	Notes
(Teflon)	PTFE	<ol style="list-style-type: none"> 1. Chemical stability is good, but chlorine element and metal sodium in the melting state have a certain corrosion resistance to the product. 2. It is hydrochloric acid, sulfuric acid and aqua regia-resistant and organic solvent has no effect on it. 3. Bad wear resistance and adhesive properties, excellent electrical insulating property, but bad corona resistance. 	<ol style="list-style-type: none"> 1. Long term usage temperature of the flowmeter is -10~+120°C. 2. For use in measurement of most of strong corrosive media such as strong acid, alkali, oxidant, but not suitable for KOH, nitric acid, hydrofluoric acid, etc. 3. Health media. 	<ol style="list-style-type: none"> 1. Hydrochloric acid, sulfuric acid, aqua regia. 2. Other most strong acids, alkalis and oxidants. 	<ol style="list-style-type: none"> 1. Not suitable for KOH, nitric acid, hydrofluoric acid. 2. Generally not for use in measurement of electrolyte, e.g. NaCl solution from electrolytic tank. 3. Not suitable for media with solid particles.
	FEP	<ol style="list-style-type: none"> 1. Its chemical stability, electrical insulation property, lubricating property, non-stick property and incombustibility are similar with PTFE (F4), but the strength, aging resistance, temperature resistance and low temperature flexibility of FEP material are superior to PTFE. 2. Adhesion with metal is good; wear resistance is better than PTFE. 3. High tearing resistance 	<ol style="list-style-type: none"> 1. Long term usage temperature of the flowmeter is -40~+80°C. 2. For use in measurement of most of strong corrosive media such as strong acid, alkali, oxidant, but not suitable for KOH, nitric acid, hydrofluoric acid, etc. 3. Health media. 	<ol style="list-style-type: none"> 1. Hydrochloric acid, sulfuric acid, aqua regia. 2. Other most strong acids, alkalis and oxidants. 3. Media with less fine particles. 	<ol style="list-style-type: none"> 1. Not suitable for KOH, nitric acid, hydrofluoric acid. 2. Generally not for use in measurement of electrolyte, e.g. NaCl solution from electrolytic tank.
	PFA	<ol style="list-style-type: none"> 1. Its chemical stability, electrical insulation property, lubricating property, non-stick property and incombustibility are similar with FEP (F46), but the strength, aging resistance and temperature resistance of PFA material are superior to PTFE, FEP. 2. Adhesion with metal is good; wear resistance is better than PTFE, FEP. 3. Low smoke, fire resistance, high temperature resistance. High temperature mechanical strength is two times higher than PTFE. 	<ol style="list-style-type: none"> 1. Long term usage temperature of the flowmeter is -40~+160°C. 2. For use in measurement of most of strong corrosive media such as strong acid, alkali, oxidant, but not suitable for KOH, nitric acid, hydrofluoric acid, etc. 3. Health media. 	<ol style="list-style-type: none"> 1. Hydrochloric acid, sulfuric acid, aqua regia. 2. Other most strong acids, alkalis and oxidants. 3. Media with less fine particles. 4. Beer, saponified liquefied gas, etc. 	<ol style="list-style-type: none"> 1. Not suitable for KOH, nitric acid, hydrofluoric acid. 2. Generally not for use in measurement of slurry, coal pulp and core pulp.
Polyurethane Rubber		<ol style="list-style-type: none"> 1. Excellent wear resistance, good oil resistance. 2. High strength, good tearing resistance, bad acid and alkali resistance. 3. Bad heat resistance, generally 60°C. 	<ol style="list-style-type: none"> 1. Long term usage temperature is generally -10~+60°C. 2. Good wear resistance, suitable for fluid containing solid particles. 3. Not for use in measurement of water containing organic solvent. 	<ol style="list-style-type: none"> 1. Neutral and strong wearing ore pulp, coal pulp and mud. 2. Domestic water, industrial water, sewage and sea water. 	<ol style="list-style-type: none"> 1. The temperature of fluid ranges between 0 and 40 °C. 2. Generally not for use in measurement of media of organic solvent.
Chloroprene Rubber		<ol style="list-style-type: none"> 1. Good elasticity and tearing resistance, oil resistance. 2. Bad aging resistance, its brittleness temperature is -28°C. 3. Wear resistance is inferior to polyurethane rubber. 4. Corrosion resistance to ordinary low concentration acid, alkali and salt media, non-corrosion resistance to oxidizing media 	<ol style="list-style-type: none"> 1. Long term usage temperature is -10~+80°C. 2. Slight pollution because anti-aging agent is contained therein. 3. Suitable for measurement of low concentration acid, alkali, salt media and sewage. 	<ol style="list-style-type: none"> 1. Normal water, sewage 2. Slurry, ore pulp 	<ol style="list-style-type: none"> 1. Not for use in measurement of food. 2. Not suitable for measurement of strong acid, alkali, oxidizing media.
Ceramics		<ol style="list-style-type: none"> 1. Non-deformation at high strength, high temperature and high pressure. 2. Unique platinum-alumina metal ceramic electrode. 3. Good anti-slurry and anti-noise ability, suitable for permeable fluid. 4. Good wear resistance, which is ten times the polyurethane. 	<ol style="list-style-type: none"> 1. Suitable for high-temperature high-pressure fluid, viscous fluid, corrosive fluid. 2. Permeable fluid, slurry containing solid particles. 	<ol style="list-style-type: none"> 1. Slurry containing hard solid, corrosive fluid, viscous fluid, high-temperature high-pressure fluid. 2. Chromium sulfate, 25% of sodium hypochlorite, nitric acid, etc. 	<ol style="list-style-type: none"> 1. Not suitable for hydrofluoric acid, nitric acid, aqua regia, NaOH, 70% concentration of sulfuric acid. 2. Not for use in partial salt substances such as copper sulfate, sodium bicarbonate.

防护等级的选择 Selection of protection grade

按GB4208-84, 国际电工委员会IEC标准 (IEC529-76) 关于外壳防护等级为:

IP65为防喷水型, 即可允许水龙头从任何方向对仪表喷水, 喷水压力为30KPa (0.3bar)。出水量为12.5升/分, 喷水离仪表距离3米。
IP67为防浸水型, 即仪表可短时间全部浸入水中, 试验时最高点应在水下至少150cm, 持续时间至少为30分钟。IP68为潜水型, 应能长期在水中工作, 其浸入的最大深度由制造厂与用户协商。

防护等级选用原则应根据以上要求和仪表实际工作条件选定。若仪表在地面以下的, 经常受水淹的, 宜选IP68; 若仪表安装在地面上, 并且环境不潮湿, 则选用IP65。

Degrees of protection provided by enclosure are as follows according to GB4208-84, International Electrotechnical Commission (IEC) standards (IEC529-76):

IP65 is an anti-spray type, i.e. a water faucet is allowed to spray water to the instrument in any direction. The pressure of spray water is 30KPa (0.3bar). Water yield is 12.5 liters/minute. The distance between spray water and the instrument is 3m. IP67 is an anti-immersing type, i.e. the instrument can be totally immersed in the water in a short time. The highest point is 150cm below the water during test. The duration time is 30min. IP68 is a submerged type, which can work in the water for a long period. The maximum depth immersed is negotiated by manufacturers and users.

The selection principles of protection grade are determined by the abovementioned requirements and actual working conditions of the instrument. If the instrument is installed underground and often immersed under water, it's suggested to select IP68. If the instrument is installed above the ground and the environment is not wet, choose IP65.

传感器接地 Sensor ground

由于电磁流量计的感应信号电压很小, 容易受噪声的影响。其准电位必须与被测液体相同。因此, 传感器的基准电位(端电位), 转换器和放大器的基准电位都与被测液体相同, 而液体电位又应与地电位相同电磁流量计配有接地环, 其作用是通过与液体接触, 建立液体接地, 同时保护内衬。仪表接地如下图所示:

Because the voltage of sensing signals of the electromagnetic flowmeter is small, it is easily affected by the noise. The reference potential must be the same as the measured fluid. So the reference potential (terminal potential) of the sensor, the reference potentials of converter and amplifier are the same as the measured fluid. And the fluid potential should be the same as the ground potential. The electromagnetic flowmeter is equipped with a grounding ring, which plays a role in establishment of fluid ground by contacting the fluid, at the same time, protecting the lining. The instrument ground is as shown below:

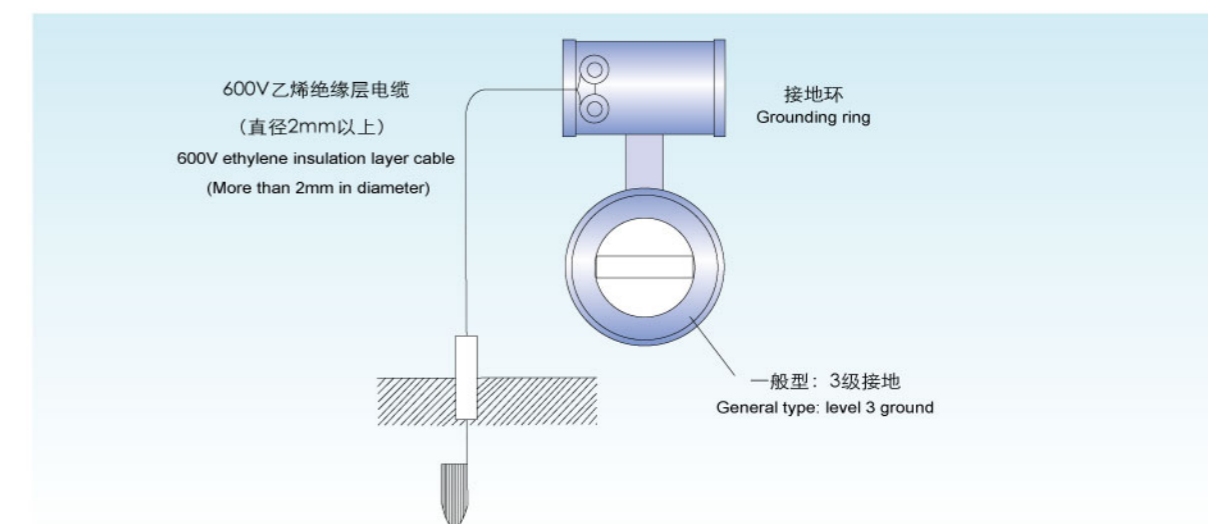

噪声抑制 Noise suppression

电磁流量计不要安装在那些容易引起感应干扰的电动机、变压器或其它电源附近。
The electromagnetic flowmeter cannot be installed near the motor, transformer or other power supplies easy to cause inductive interference.